



FOX / COYOTE OPERATOR'S MANUAL



SIEBRING
GEORGE, IOWA 51237 U.S.A. MFG. INC.
PHONE: (712) 475-3317 "SINCE 1910"



ATTENTION:

For Sprayer and pump maintenance:

<https://siebringmfg.com/videos/>

TABLE OF CONTENTS:

1. Cover
2. Table of Contents
3. Warranty / Shading Information
4. Features
5. Accessories
6. SS Accessories
7. General Safety
8. Consumer Product Safety Commission Warning
9. Precautions / Coyote Back-flush Procedures
10. Fox Back-flush Procedures
11. Operating Instructions / Cordage Chart
12. Operating Instructions (continued)
13. How it works
14. Tank & Components
15. Tank & Component Diagram – 2019 & before
16. Tank & Component Diagram – 2020 & after
17. Unloader Description
18. Unloader Diagram – Spray Mode
19. Unloader Diagram – By-pass Mode
20. Pump / plumbing – By-pass mode
21. Pump / plumbing – Re-circulate mode
22. Flow Diagram – Pump / Plumbing
23. Flow Diagram – Typical system
24. Electrical Diagram – CL3514 Low Voltage 9-22-22 TO CURRENT
25. Electrical Diagram – CL3514 High Voltage 9-22-22 TO CURRENT
26. Electrical Diagram – CL3514 Low Voltage
27. Electrical Diagram – CL3514 Low Voltage
28. Electrical Diagram – Marathon G396 Low Voltage
29. Electrical Diagram – Marathon G396 High Voltage
30. Troubleshooting Index
31. Troubleshooting (continued)
32. Troubleshooting (continued)
33. Troubleshooting (continued)
34. Troubleshooting (continued) / Winterizing
35. Parts List
36. Parts Diagrams
37. Parts Diagrams (continued)
38. Stainless Steel Parts
39. Warning & Caution Labels

Included: CAT 2SF Data Sheet, CAT SF Service Manual & Honda Manual (if applicable).

CONDITION OF SALE
SIEBRING MANUFACTURING, INC.
GEORGE, IA 51237

Pursuant to Magnuson-Moss Warranty Federal Trade Commission Improvement Act P.L. 93-637, 88 STAT.2183-2193; U.P.C. 2301-2312 (Jan. 4, 1975), the following limited warranty will now replace all prior warranties issued by Siebring Manufacturing, Inc.

We warrant the equipment manufactured by us to be free from defects in material and workmanship under normal use and service, our obligation under this warranty being limited to replacing at our factory any product, or parts thereof, which shall within one year after delivery thereof to the original purchaser be returned to us with transportation (UPS Ground) charges prepaid, and which our examination shall disclose to our satisfaction to have been thus defective. We neither assume nor authorize any other person to assume for us any other liability in connection with such equipment. "Overnight", "Next Day" or any shipping method other than UPS Ground will be the responsibility of the customer. This warranty shall not apply to any equipment which shall have been repaired or altered outside of our factory in any way so as to affect its stability and reliability, nor which has been subject to misuse, negligence or accident, nor to any equipment, which shall have been operated beyond factory rated capacity. We shall not be liable for consequential damages caused by defective materials, equipment or parts warranted by their respective manufacturers.

Siebring MFG will not warranty any sprayer manufactured with brass components that has been used to apply Zeritol or similar products. Sprayer warranties on units manufactured with stainless steel pumps and associated components will be honored.

Any implied warranty (including the warranty of merchantability), to the extent permitted by law, is excluded.

We will not grant any allowance for any repairs or alterations without written approval of an executive officer, and we reserve the right to make changes in design, or to make additions to, or improvements in, our products without imposing any obligations upon the company to install them on products previously manufactured.

Shading:

Continental Products Company's "Kool Ray" liquid shading products are the only brands authorized for use in the Siebring "Mist R' Drench," "Fox" and "Kruser" line of sprayers.

DO NOT USE LATEX PAINT!

Use of unauthorized products can damage the sprayer pump and components and will void the warranty.

Prior to applying shading, install a 0° tip and a 50 mesh screen (not included) in the filter bowl assembly.

FOX Features & Accessories

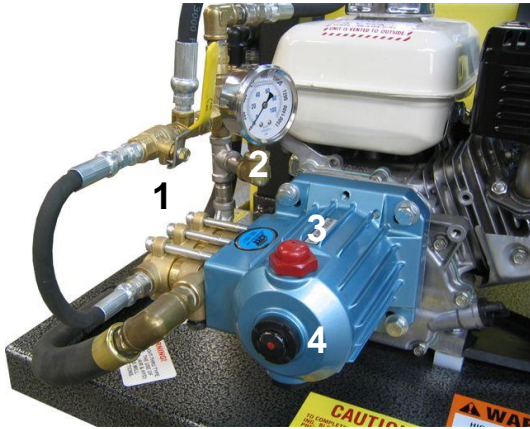

1. Bypass Valve
2. Liquid filled gauge
3. Oil filler cap
4. Oil sight glass
5. Brake to prevent unwanted spool run-off
6. Crank Handle
7. Reel Lock
8. Filter Bowl Assembly
9. Quick Disconnect
10. Bottom Tank Drain
11. Included Accessories (see next page)
 - 2 Spray guns
 - 2 - 18" & 1 - 12" wand
 - 1 - 12" curved (hook) extension
 - 3 piece misting tip & water breaker
 - Back-flush fitting
 - 0° & 15° pressure nozzles

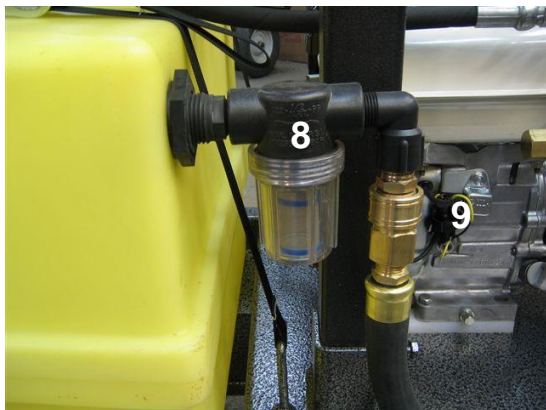



Fox, Coyote, MD83, MD83BW, MD100, MD200 Included Accessories:

- | | |
|------------------------|----------------------|
| 1. Small water breaker | 7. 12" Hook |
| 2. 18" extension (2) | 8. Backflush fitting |
| 3. Gun (2) | 9. 12" Extension |
| 4. Cap | 10. Disk |
| 5. 0° Tip | 11. Core |
| 6. 15° Tip | 12. Brass Strainer |

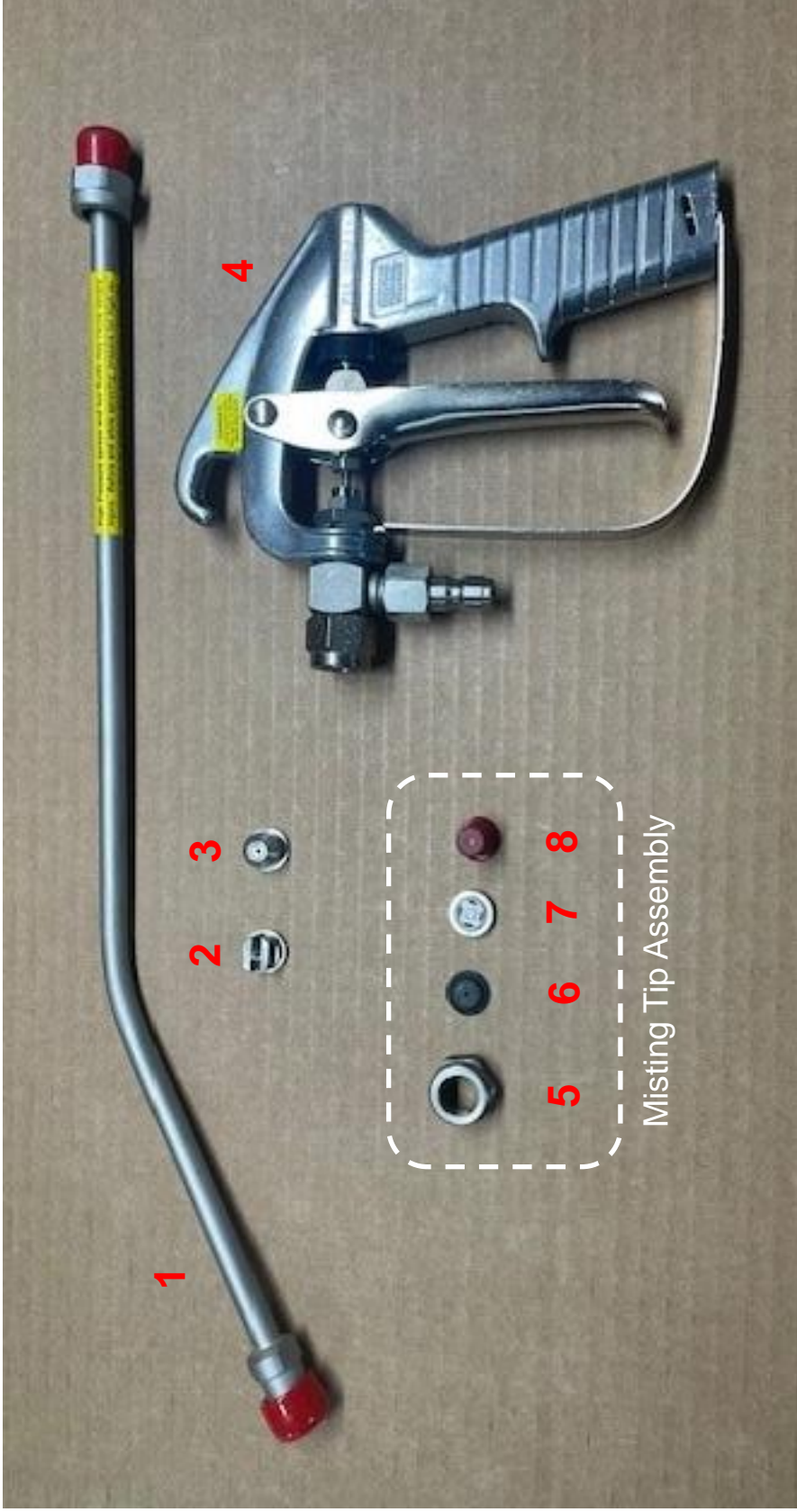

STAINLESS STEEL SPRAYERS – INCLUDED ACCESSORIES:

(Fox, Coyote, MD83, MD83BW, MD100, MD200)

- | | |
|------------------|--------------------|
| 1. 18" Extension | 5. SS Cap |
| 2. 15° Tip | 6. SS Disk |
| 3. 0° Tip | 7. SS Core |
| 4. SS Gun | 8. Plastic Stainer |

GENERAL SAFETY

1. **WARNING** – Do not pump flammable or explosive fluids such as gasoline, fuel oil, kerosene, etc. Do not use in explosive atmospheres. The pump should only be used with liquids compatible with the pump component materials. Failure to follow this warning can result in personal injury and/or property damage and will void the product warranty.
2. Do not run the pump faster than maximum recommended speed.
3. Do not attempt to pump at pressures higher than rated, motor damage may result.
4. Maximum liquid temperature through pump is 140°.
5. Make certain that the power source conforms with the requirements of your equipment (see cord chart on page 8).
6. Do not operate machine with belt guard, shaft guard or similar safety devices removed.
7. Prior to servicing, disconnect power, stop engine.
8. Relieve system pressure prior to servicing.
9. Drain all liquids from system before servicing.
10. Secure quick couplers on lines and guns before starting the pump. A loose quick coupler may cause a hose whip around under pressure causing personal injury and/or property damage.
11. Check hoses for weak or worn conditions before each use. Make certain that all connections are tight and secure.
12. Periodically inspect the pump and system components. Perform routine maintenance as required. See maintenance section in this manual, CAT pump Service Manual and Honda engine manual as applicable.
13. Electric motors must be adequately grounded.
14. Do not operate a gasoline engine in an enclosed area. Be sure the area is well ventilated.
15. Gasoline is a highly combustible fuel. The improper use, storage or handling of gasoline can be dangerous. Never fill or touch a hot engine.
16. Do not handle a pump or motor with wet hands or when standing on a wet or damp surface.
17. Use only pipe, hose and fittings rated for the maximum P.S.I.G. rating of the pump. If an unloader is used, use pipe, hose and fittings rated for the pressure at which the unloader bypass operates.

WASHERS DANGEROUS, SAFETY PANEL WARNS

The U.S. Consumer Product Safety Commission has issued a warning to consumers who use electrically powered pressure washers for cleaning milk tanks, spray tanks, and other farm equipment.

According to a federal safety alert, consumers can receive a fatal electrical shock from pressure washers if the power cord connections become wet or an internal short exists.

Since pressure washers are used to spray water, the power cord, washer and consumer are often wet, and this can be fatal, especially if the machine is not properly grounded, the report explained.

Consumers should not use adaptor plugs to connect the three-wire plug to a two-prong household receptacle without properly grounding the adaptor plug. Power cord connections should never be allowed to lie in water.

The commission urges these precautions:

- Always plug a three-wire grounded pressure washer into a properly grounded receptacle. If possible, use a receptacle protected by a ground fault circuit interrupter (GFCI).
- Check all flexible cords, plugs and sockets before each use. Replace any damaged items.
- If an extension cord must be used, use the heavy-duty three-wire, properly grounded type, and keep the power cord connection out of the water and away from the item being washed.
- Wear eye protection when using sprayers or pressure washers.
- Wear rubber-soled footwear when operating the washer.
- Never cut or splice the power cord or extension cords.
- Do not leave hoses or cords where they can be run over and damaged.
- Never remove the grounding prong from the power cord plug.
- Never operate the washer after it has tripped a ground fault interrupter or circuit breaker without first having it examined by a competent repair person.
- Never allow children to operate a pressure washer, and keep them away from the washer when an adult is using it.
- Never spray the cleaner at yourself or others. The pressure can cause the water and cleaner to blast under the skin.
- Never start the washer until you have checked to make sure all coupler hose connections are in place and locked.

FOR MORE INFORMATION, CONSUMERS CAN CALL THE CPSC TOLL-FREE HOTLINE, 800-638-CPSC.

FOX PRECAUTIONS

ALWAYS - RINSE AND FLUSH OUT THE FOX AFTER EACH USE.

ALWAYS - DRAIN ANY REMAINING FLUIDS FROM THE SPRAYER TO PROTECT IT FROM FREEZING.

ALWAYS - READ AND FOLLOW ALL DIRECTIONS OF THE CHEMICAL MANUFACTURER (CHECK MSDS).

ALWAYS - PUT FRESH, CLEAN WATER IN THE FOX AND TEST THE SPRAYER FOR PROPER OPERATION BEFORE ADDING ANY SPRAYS.

ALWAYS - WEAR PROTECTIVE GEAR WHEN MIXING OR APPLYING ANY CHEMICALS. THIS INCLUDES MASK, RESPIRATOR, GLOVES, GOWN, ETC.

ALWAYS - MAINTAIN THE FOX IN GOOD REPAIR. THIS WILL HELP PREVENT LEAKS, ETC. AND ADD TO THE LIFE OF THE MACHINE.

NOTE: See next page for Fox sprayer backflush/pump flushing info.

BACKFLUSH PUMP FITTINGS FOR COYOTE SPRAYER

PARTS INCLUDED:

- 1 – 50MP QUICK COUPLER
- 1 – GARDEN HOSE SCREEN
- 1 – ¾ X ½ SWIVEL ADP/GARDEN HOSE FITTING

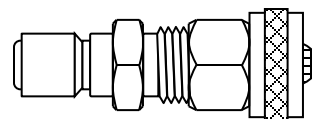

HOW TO USE

****TANK MUST BE EMPTY****

1. DISCONNECT BLACK RUBBER SUCTION HOSE FROM TANK AT QUICK COUPLER
2. INSERT SUPPLIED FITTINGS INTO HOSE QUICK COUPLER
3. ATTACH GARDEN HOSE TO FITTING
4. TURN ON WATER SUPPLY
5. RUN PUMP/SPRAY TO FLUSH PUMP

***** WINTERIZE PUMP IF FREEZING TEMPERATURES ARE EXPECTED *****

FOX SPRAYER CLEAN & FLUSH GARDEN HOSE ADAPTER

Note: It is recommended to clean and flush the pump and related components after each use.

1. Remove the tank lid and pull tank sump pick-up from tank.

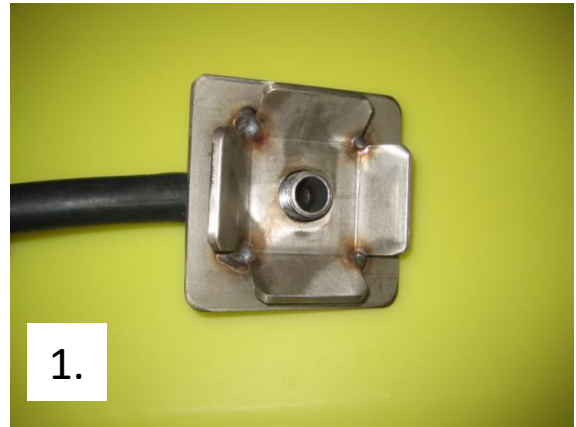
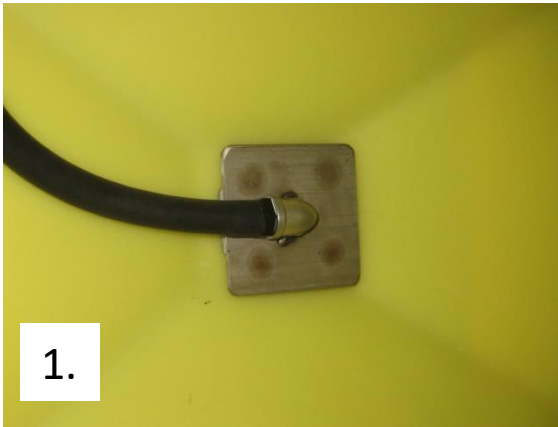

2. Connect garden hose adapter to the lower, threaded portion of the tank sump pick-up assembly.



3. Attach garden hose to garden hose adapter and flush as required.

FOX SPRAYER OPERATING INSTRUCTIONS

PRIOR TO START UP

Completely uncrate unit. Inspect for shipping damages that could interfere with unit operation. Check for crating/shipping materials lodged in pump/motor assembly, belt drive (if applicable) steering mechanism and wheel & tire area. Check for foreign debris in sprayer tank.

Read this manual and comply with all of the safety instructions. Familiarize yourself with the operating instructions and component location prior to using the unit.

If you have a gas engine powered unit, read and familiarize yourself with the Honda Owner's Manual.

Read and be familiar with the CAT Pump manual and operating instructions.

If electrically powered unit, ensure adequate power and extension cords are available to operate the unit (see chart below).

Wire Size for 115 & 230 Volt Single Phase Circuits
Distance – Motor to Fuse or Motor to Meter Box

MOTOR HP	100 FT.		200 FT.		300 FT.		500 FT.	
	115V	230V	115V	230V	115V	230V	115V	230V
1/4	# 14	# 14	# 10	# 12	# 8	# 10	# 6	# 8
1/3	# 12	# 14	# 10	# 12	# 6	# 10	# 4	# 8
1/2	# 10	# 12	# 8	# 10	# 6	# 8	# 4	# 6
3/4	# 10	# 12	# 6	# 10	# 4	# 8	# 2	# 6
1	# 8	# 10	# 6	# 8	# 4	# 6		# 4
1 ½	# 4	# 10	# 0	# 8		# 6		# 4
2		# 8		# 6		# 4		# 2
3		# 8		# 6		# 4		# 2
5		# 6		# 4		# 2		# 0

Check “Quick Couplers” for secure connection: Hose reel to unloader, Return line to tank & Supply (suction) line on the bottom of the tank.

Open valves: Bypass valve (unloader) & Supply (suction) valve below tank.

Depress spray gun trigger during start-up to allow for “Load Free” run-up.

Check sight glass on filter bowl during start-up. Air bubbles during operation may indicate a cracked filter bowl or missing o-ring or gasket.

START UP

1. Put 10 gallons of water into the sprayer tank. **DO NOT ADD SPRAY YET!!!**

TESTS

2. Test the sprayer. It should have up to 800 PSI when spraying with the misting wand. The bypass valve must be shut for this test.

TANK AGITATION

3. The water in the tank should be agitating whenever the pump is on (but not spraying) or when the ball valve is open.

LEAK INSPECTION

4. Check for any leaks. Find the source of any and all dripping water. Be sure to confirm that the filter is clean and that the filter bowl is tightly screwed on.

ADD SPRAY

5. Additional water and spray may now be added to the tank. Any products that are heavy solids may be added to the tank slowly. Additional water should be added to the tank to keep the powder well diluted. Some sprays may also be harmful to the pump seals if used at full strength. Check CAT pump manual for compatibility.

CLEAN UP

6. Cleaning herbicide from the Sprayer: Use one quart of household ammonia per 60 gallons of water (1:240 ratio). Stir well!! Start the pump and run the unit until the ammonia fills the MD83 hose and wand. Allow to stand for 24 hours.

RINSING

7. Flush with fresh water. Triple rinse with clear water. Winterize for cold weather.

How it Works

For twenty-five years, Siebring Manufacturing has been listening to and incorporating customer suggestions and criticisms to develop a dependable and user friendly product. The paragraphs below briefly describe the Siebring "FOX" line of sprayers and how they operate.

First, when you start the GAS-POWERED ENGINE, or ELECTRIC MOTOR, of your sprayers, the motor drives a crankshaft inside the water pump that starts the pistons or plungers.

Fresh water, coming in from your fluid supply tank, through the intake hose, picking up fluid near the bottom of the sprayer tank to the inlet side of the pump manifold.

The CAT pump produces flow and sends it to the unloader. Pressure is created by restricting the flow at the nozzle. At a given flow, the smaller the restriction nozzle the higher the pressure; the larger the restriction nozzle the lower the pressure.

The unloader acts like a traffic cop, sending the preset amount of flow through the hose and towards the spray gun and nozzle, and sending the by-pass fluid back to the pump manifold or through the recirculation hose and back into the tank (depending on the ball valve position). See page 14 - 16 to learn about the unloader.

Water is pushed through the high pressure hose, through the spray gun that's controlled by a trigger. The trigger on the spray gun is actually a valve that controls the flow through the wand. Squeezing the trigger opens the valve, releasing the trigger closes the valve. The spray gun has a trigger lock feature that will lock the trigger closed for safety to prevent accidental activation of the spray gun.

The pump produces flow. The pressure is created by restricting the flow through the use of an appropriate sized nozzle or tip.

The sizes and flow rate calculations of the nozzles and tips provided with the Fox sprayer line have been predetermined at the factory. Altering the size and flow rates of the nozzles and tips can hinder sprayer performance. Wear in a nozzle or tip can cause pressure drop.

Note: Spray angle does not affect nozzle flow rate.

35 GALLON TANK COMPONENTS & DESCRIPTIONS

(See page 13 for tank & component diagram)

1. Tank Lid – (spin-on lid) vented, allows access to the tank for filling & mixing and allows air to displace fluid being pumped out.
2. 35 gallon horizontal tank - 29" overall length, 19" in wide & 18.5" high. Gallon markers on side. Tapered bottom sump for complete fluid pick-up, draining and cleaning.
3. Buckle & Straps – Secures tank to sprayer frame.
4. Suction Fitting Assembly – Connected to the pump suction line and located just off the bottom of the sump in the tank. The fitting is raised off the bottom slightly and has two ¼" holes in the end to prevent unmixed chemical powder and to filter out large chunks of unmixed chemicals, shading or debris in the water such as chemical packaging materials.
5. Suction Hose – ¾" non-reinforced hose. Supplies water/chemical to pump.
6. Filter assembly – Mounted in the supply line to remove dirt & sediment before the fluid enters the pump. The 4 main components are the housing assembly, bowl, gasket and screen.
7. Filter Bowl & gasket.
8. Mesh Filter screen – 3 screen sizes are available for various applications; 30, 50 & 80. Siebring Fox sprayers are delivered with # 80 screens unless otherwise specified.
9. Plastic Street Elbow – connects suction fitting assembly with the suction hose and the by-pass assembly with the bypass hose.
10. Drain valve – Located in the lowest part of the tank for tank draining. Male threads are ½" NPT.
11. By-pass hose – Approximately 10% fluid by-pass from the unloader returns to the tank to agitate fluids and for suspending wettable powders.
12. Back-flush Assembly – Installed in the suction line, the assembly has an adapter to connect a standard garden hose in line to the pump. The fitting can be used for flushing, cleaning and winterizing.

FOX 35 GALLON TANK & COMPONENTS

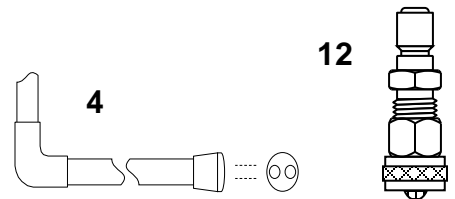
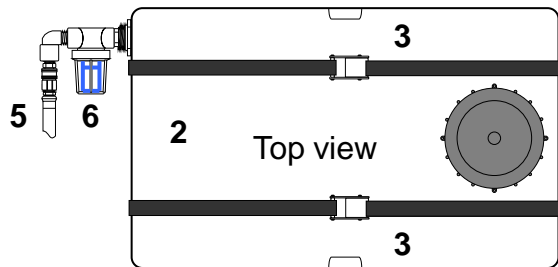
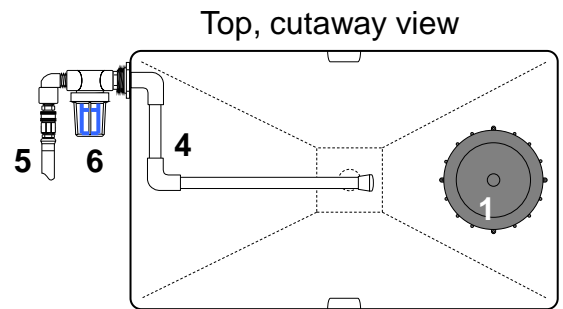
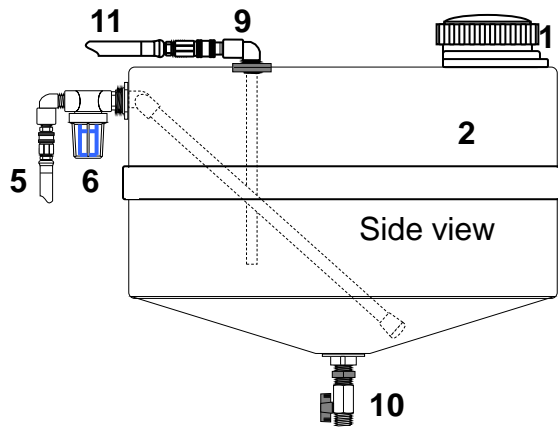
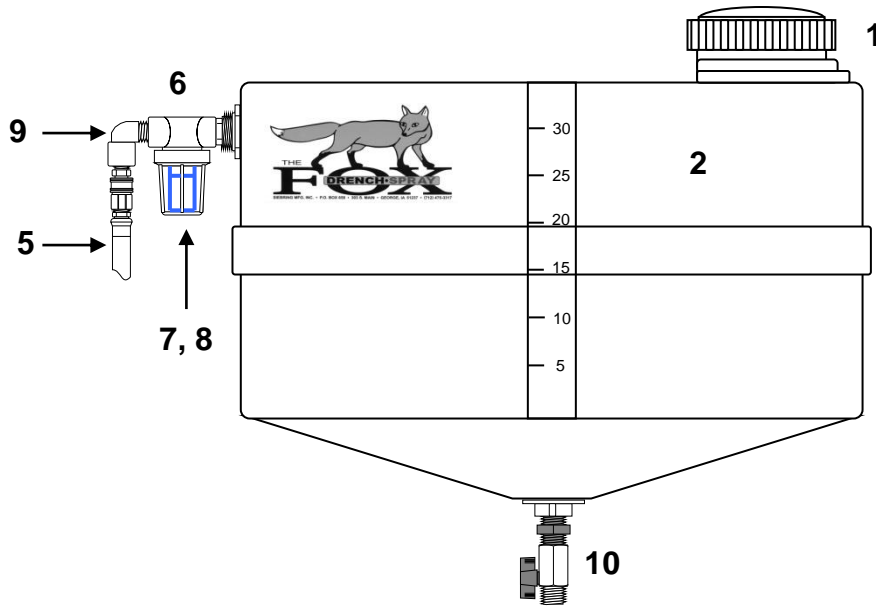

- | | |
|-----------------------------|--------------------------------|
| 1. Tank Lid | 7. Filter Bowl |
| 2. Tank | 8. Mesh Filter screen |
| 3. Buckle & Strap | 9. Plastic Street Elbow – 1/2" |
| 4. Suction Fitting Assembly | 10. Drain Valve |
| 5. Suction (supply) hose | 11. By-pass (return) hose |
| 6. Filter Assembly | 12. Back-flush Assembly |

FOX 35 GALLON TANK & COMPONENTS

2020 AND AFTER

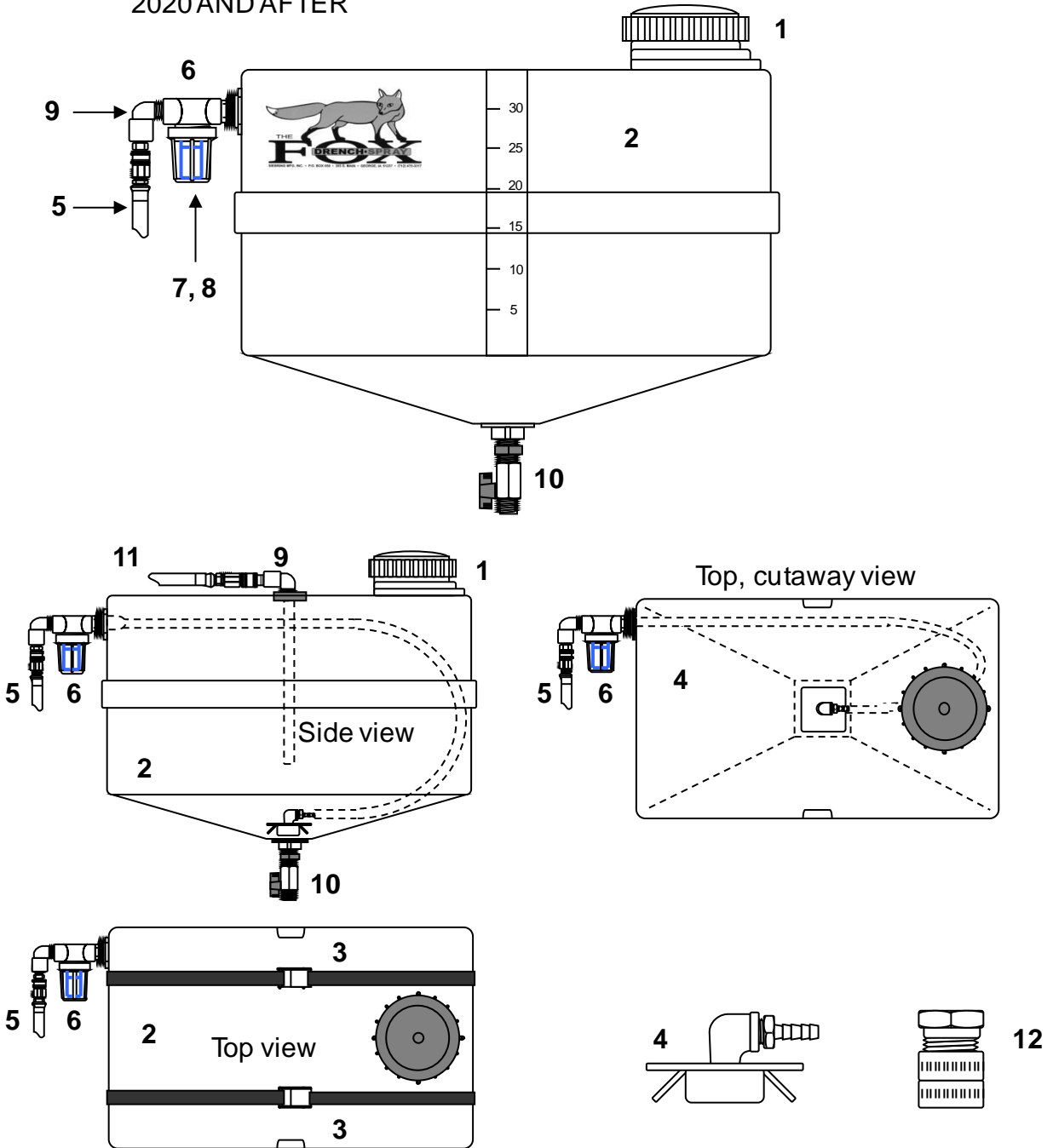

- | | |
|------------------------------|----------------------------------|
| 1. Tank Lid | 7. Filter Bowl |
| 2. Tank | 8. Mesh Filter screen |
| 3. Buckle & Strap | 9. Plastic Street Elbow – ½" |
| 4. Tank Sump pickup Assembly | 10. Drain Valve |
| 5. Suction (supply) hose | 11. By-pass (return) hose |
| 6. Filter Assembly | 12. Garden Hose Adapter Assembly |

Pressure Sensitive Regulating Unloader

This type of unloader may be referred to as a "Trapped Pressure" type or just "Pressure" type. This type of valve opens to bypass when it senses the pressure build up of the pump output having nowhere to go. The main characteristic of this most commonly used valve is how it traps the pressure in the hose when the trigger of the pressure gun is released and unloading excess pressure between the pump & unloader.

The disadvantage of this type of valve is the spike of pressure felt by the operator and sprayer/pressure washer components when the trigger is again squeezed. This creates a "kickback" effect on the gun/wand so be careful when using ladders or other types of access equipment. The "kickback" effect is most noticeable when working with pressures above 1000 PSI. The "Fox" sprayer line is factory set at 800 PSI for customer comfort and safety.

When your system uses a trigger gun that stops the water flow from the pressure pump the unloader valve must be employed. Understand that when the trigger of the gun is released the water flow to the nozzle is interrupted. The power source and the pressure pump are still running, without some pressure system safety device the water would have nowhere to go, building pressure until pump damage occurs.

Enter the Unloader Valve. The most basic function of the unloader is to act as a "traffic cop" to the water flow in your system as soon as it senses "pressure build". When the "Pressure Build" condition is met the unloader will then actuate the piston assembly to divert the water flow toward the bypass port. When this is occurring the pump is said to be in "bypass mode" and the unloader valve is said to be "cycling". This scenario ends when the trigger is squeezed alerting the unloader valve to redirect the flow to the gun and high pressure nozzle once again.

The Siebring sprayers have a ball-valve installed down stream from the pump and just before the unloader. In the open position, the majority of the by-pass fluid is directed back to the pump. In the closed position, the majority of the by-pass fluid is directed to the tank, the remainder circulates through the manifold. This design constantly supplies cool fluid to the pump & manifold, eliminating concerns regarding manifold temperatures.

Pressure Sensitive Regulating Unloader

Spray Mode

Gun trigger is depressed with gun in use. Pump flow enters from the left of the diagram (inlet port), passes through the unloader, out of the outlet port, to the gun.

CAUTION: A minimum bypass of 5 - 10% of the UNLOADER RATED FLOW CAPACITY is required for proper unloader performance.

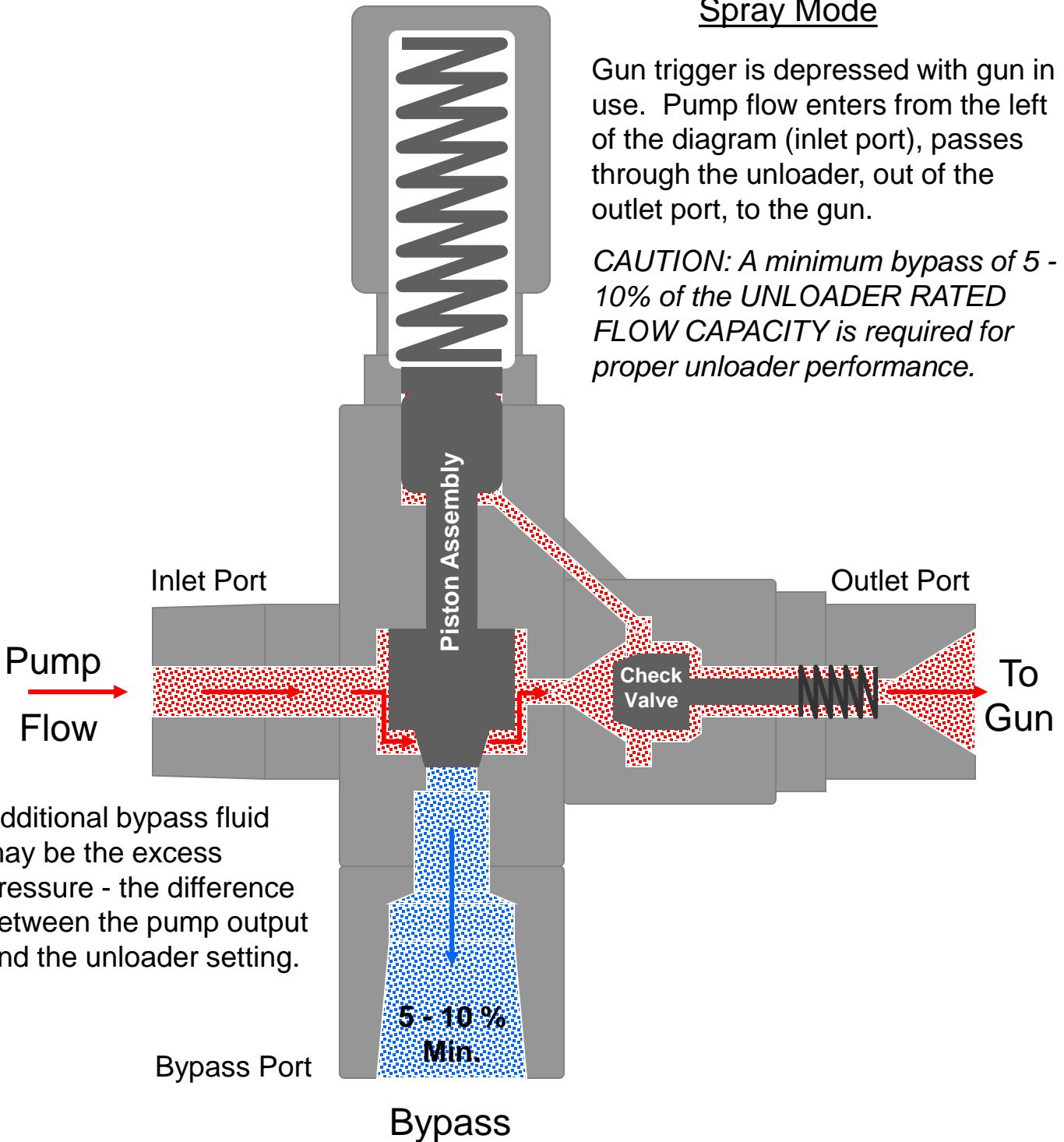

Pressure Sensitive Regulating Unloader

WARNING: DO NOT OPERATE THE PUMP IN BYPASS MODE LONGER THAN 2 MINUTES.

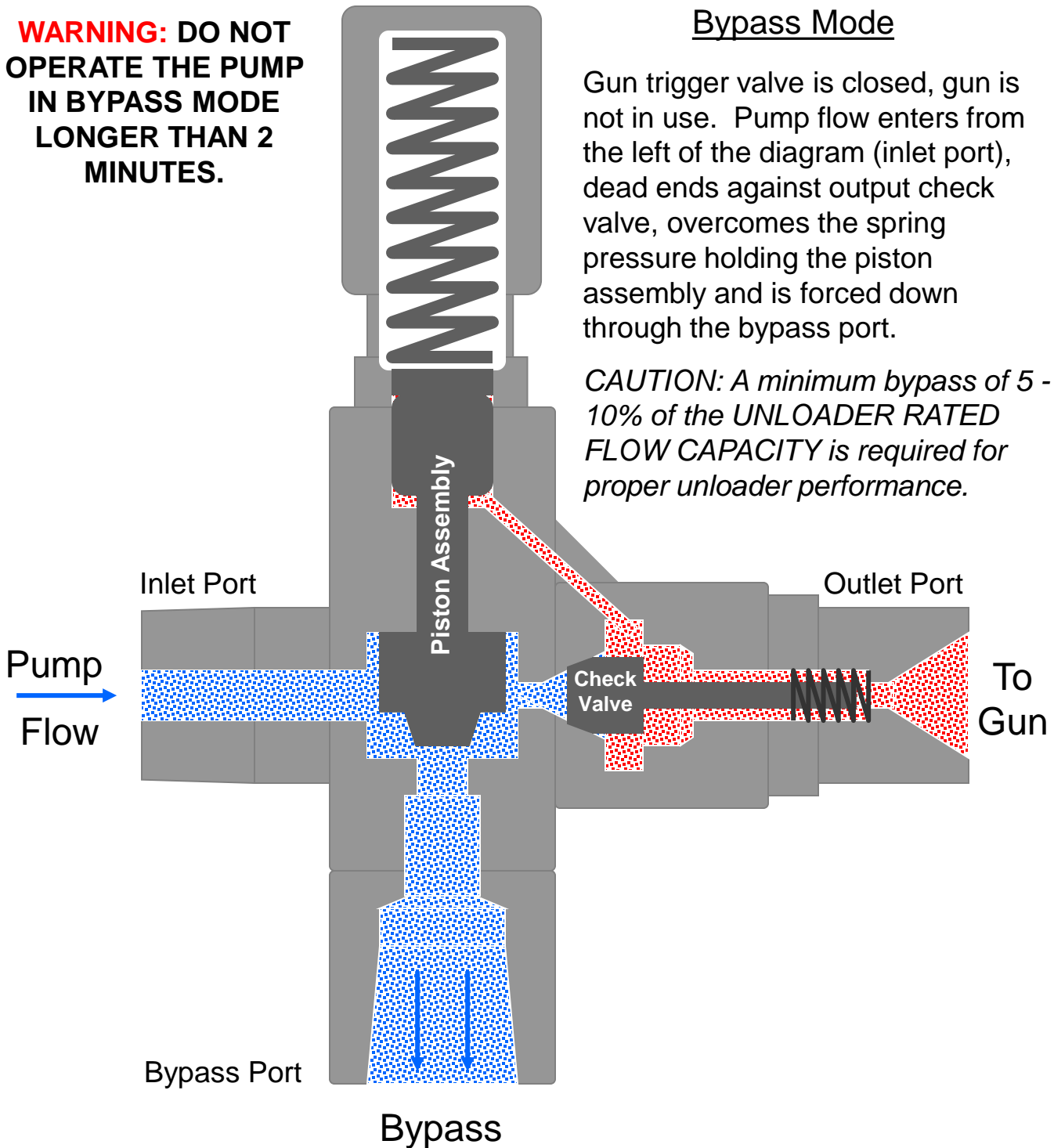

Direct Drive Pump & Associated Plumbing

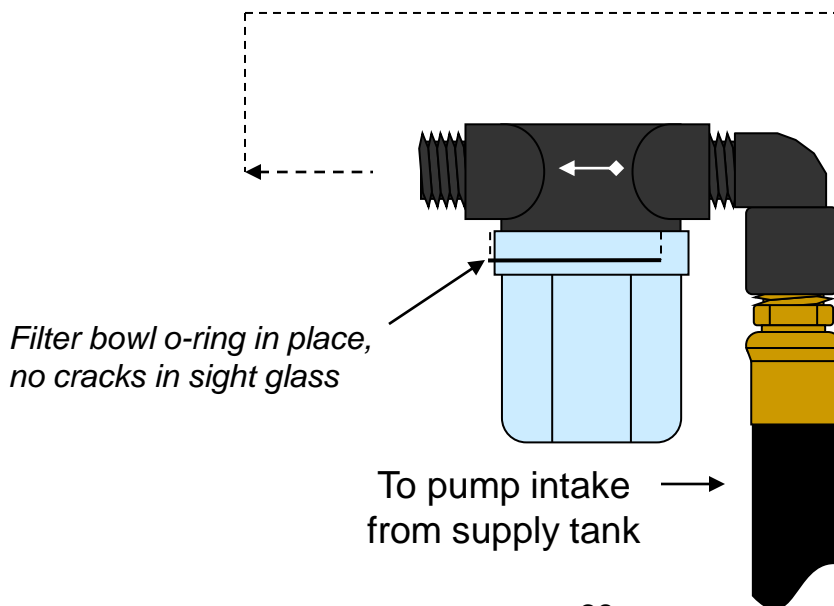
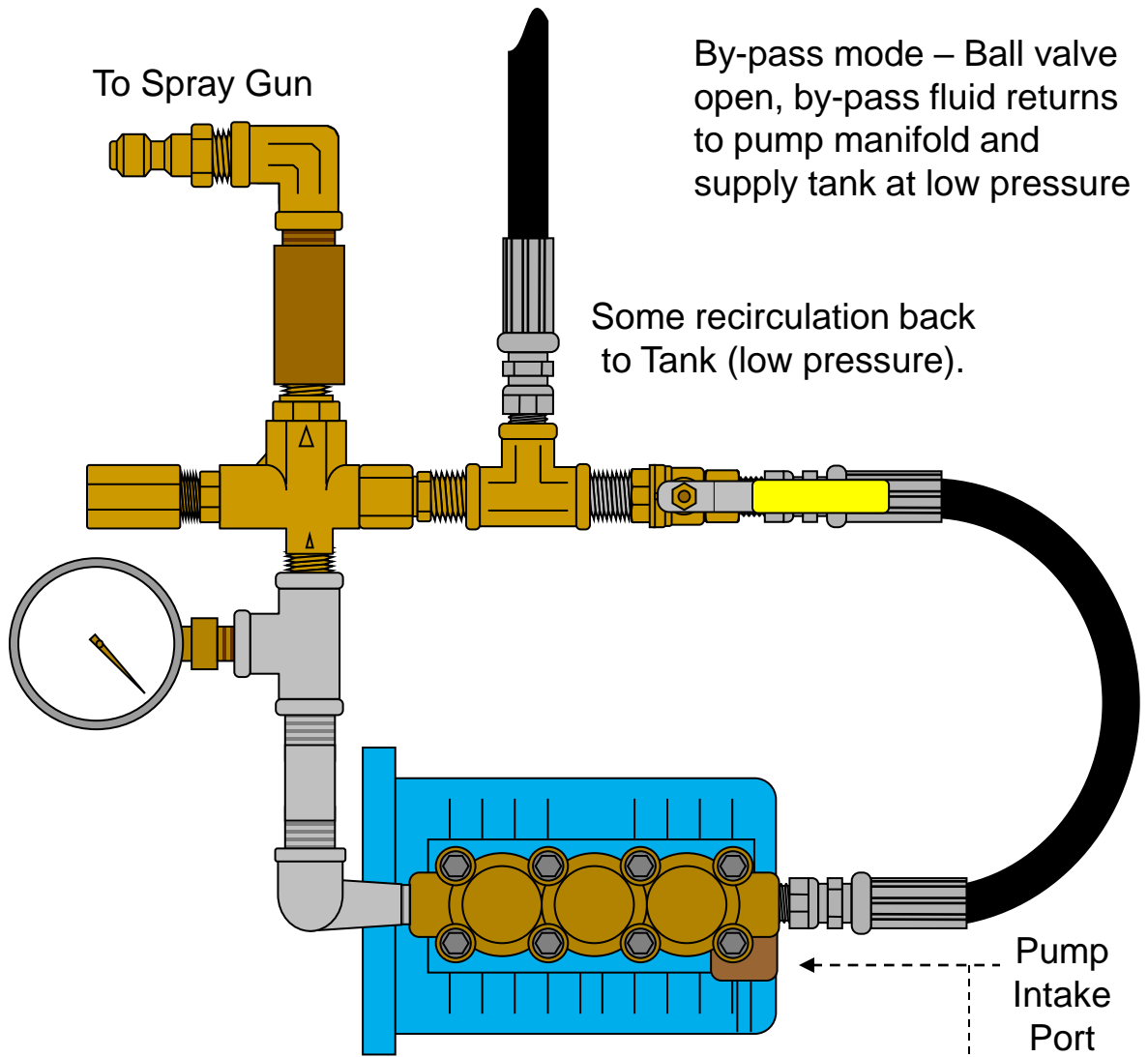

Direct Drive Pump & Associated Plumbing

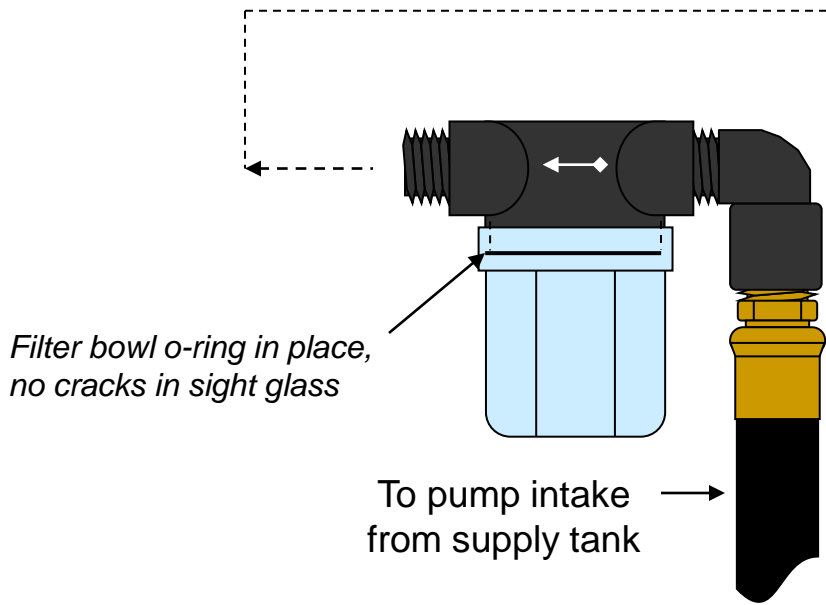
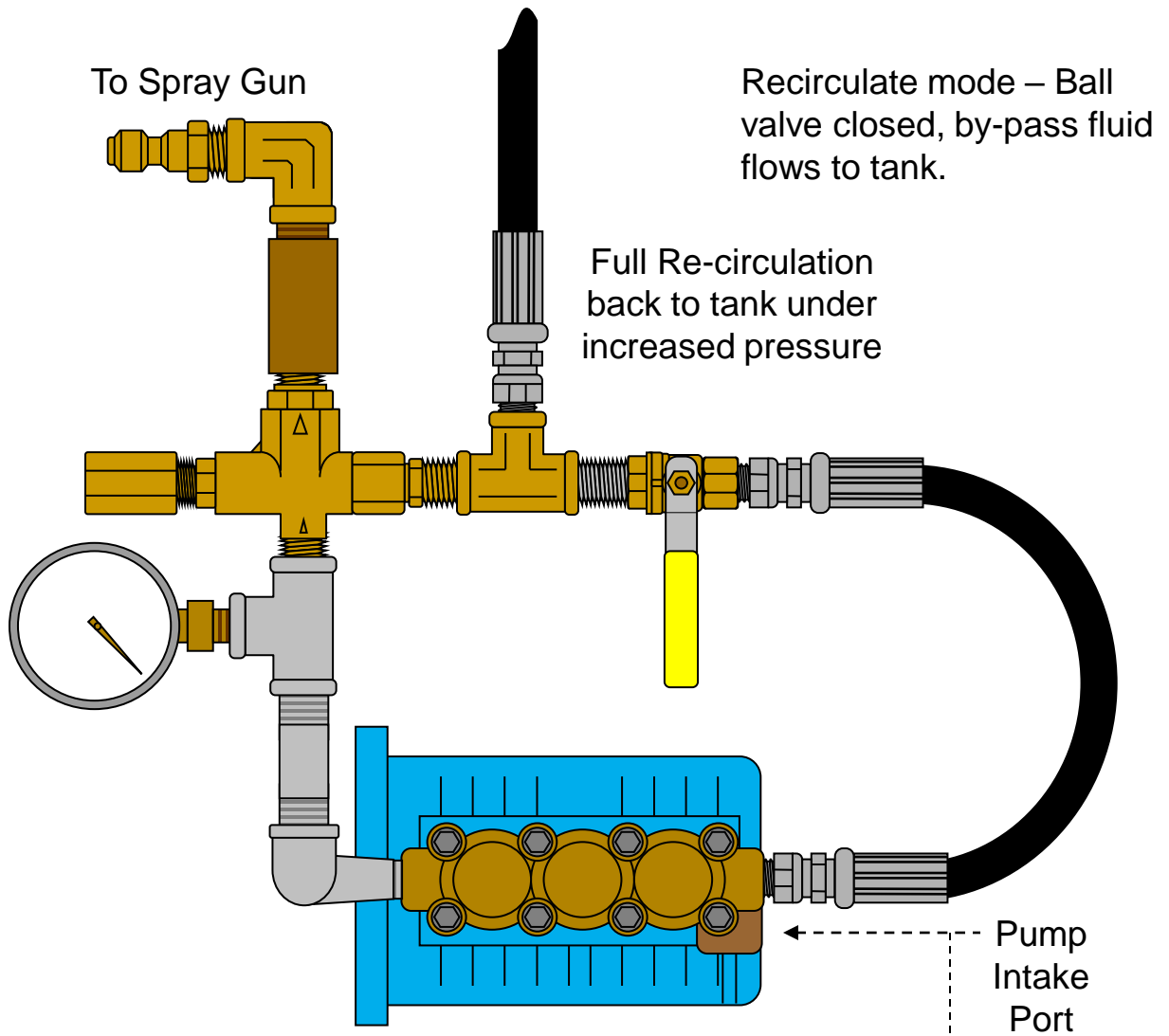

Typical Flow Diagram – Siebring “Fox” Sprayer

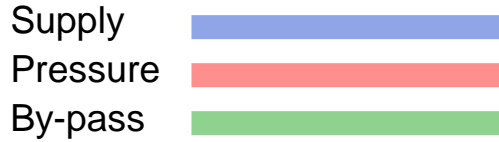

By-pass mode – Ball valve open, Unloader by-pass fluid returns to pump manifold. Pressure gauge drops to near zero (0 – 25 PSI).

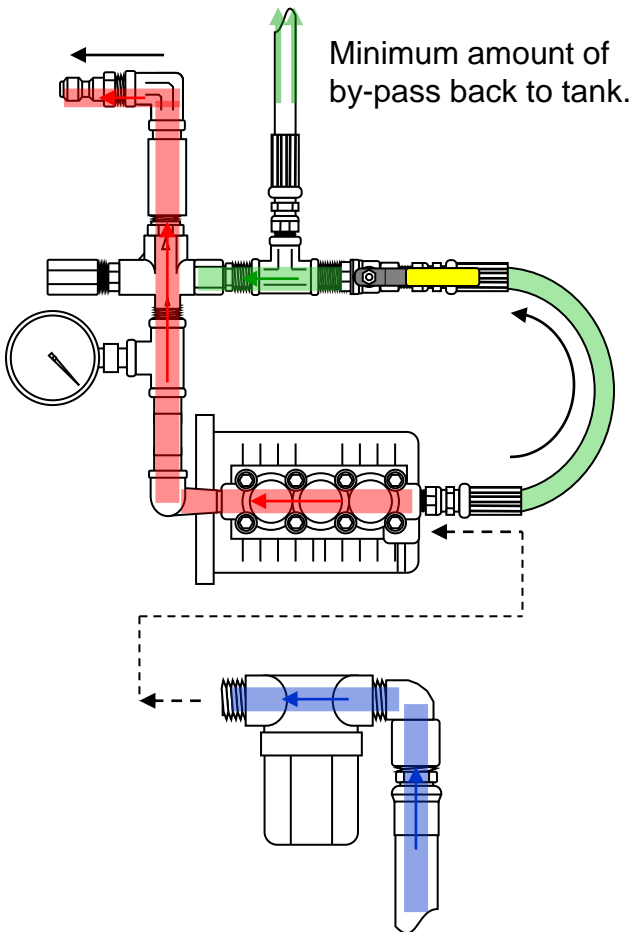

Recirculate mode – Ball valve closed, unloader by-pass fluid flows to tank. Select this mode to mix chemicals, keep wettable powders suspended or to check pump operating pressure.

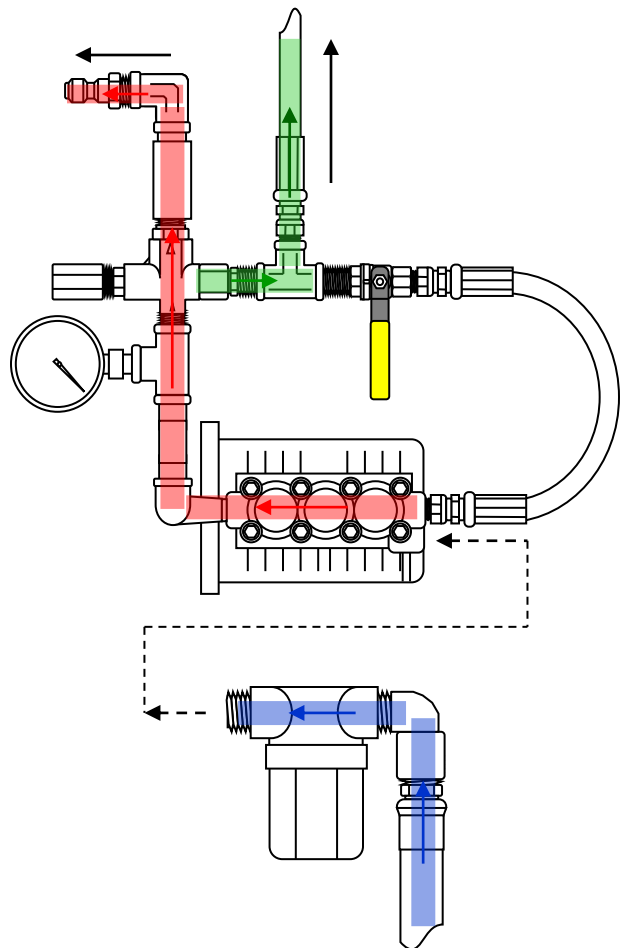

Flow Diagram - Typical

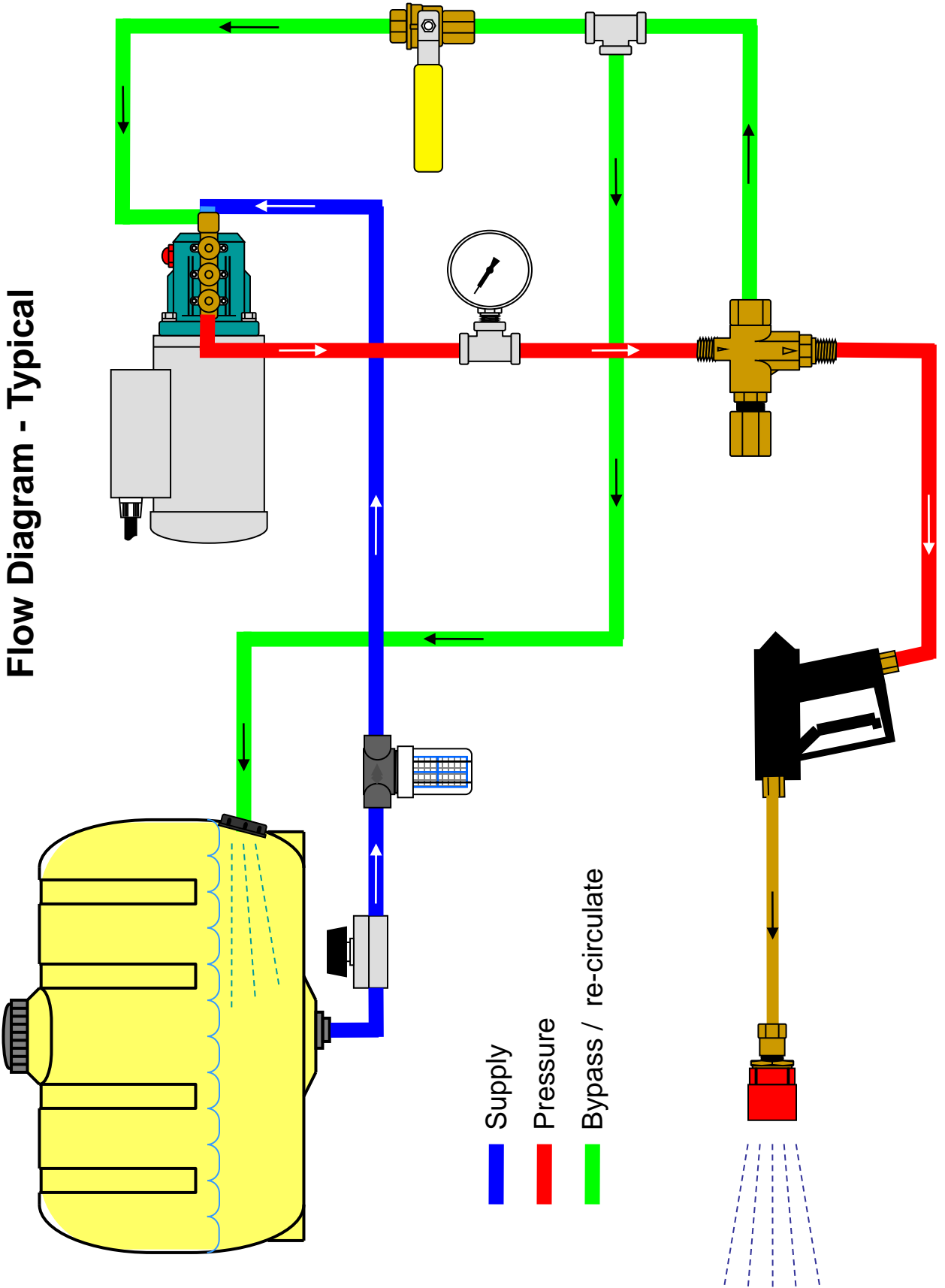

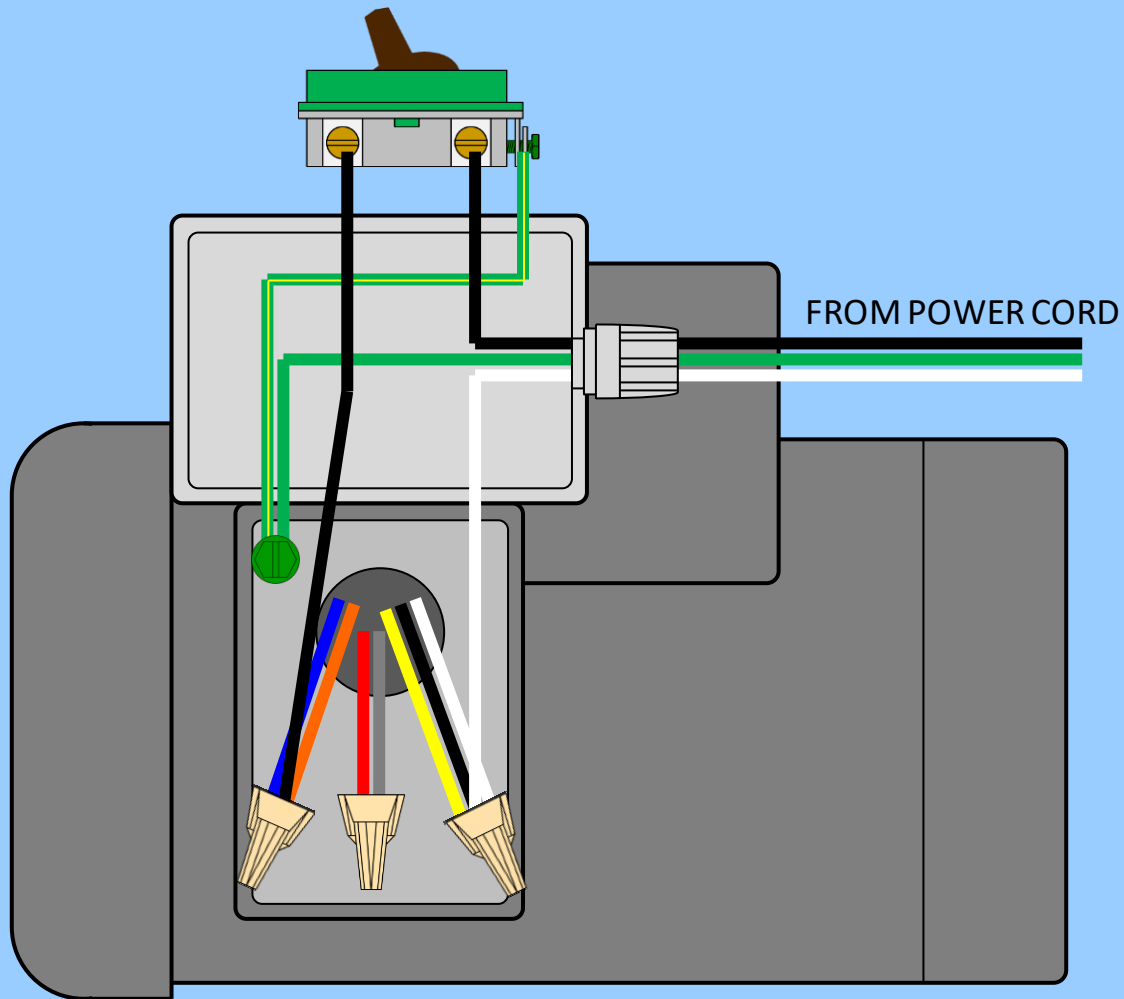

Note: Standard rotation is CCW facing end opposite shaft extension

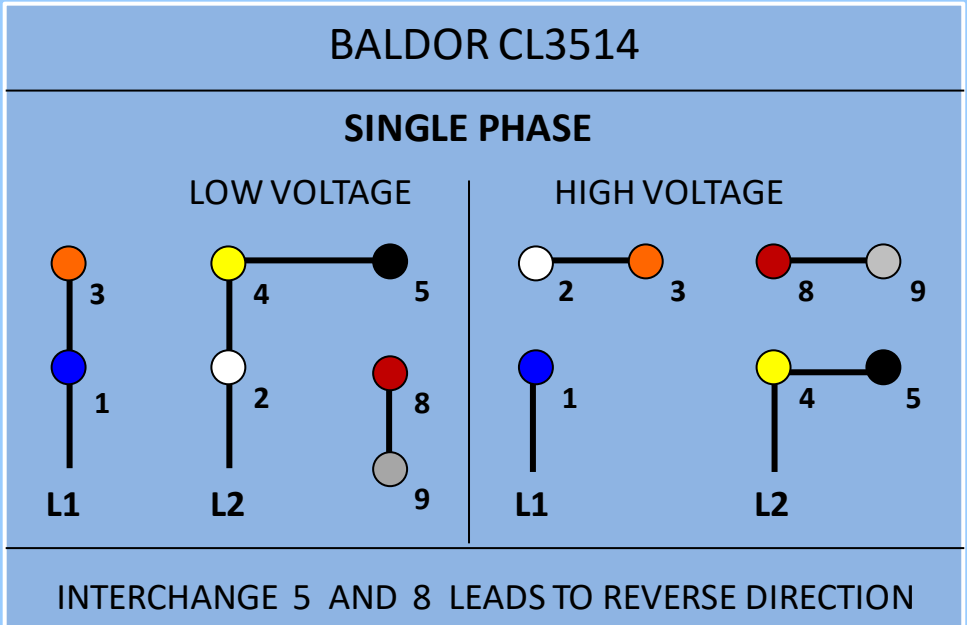

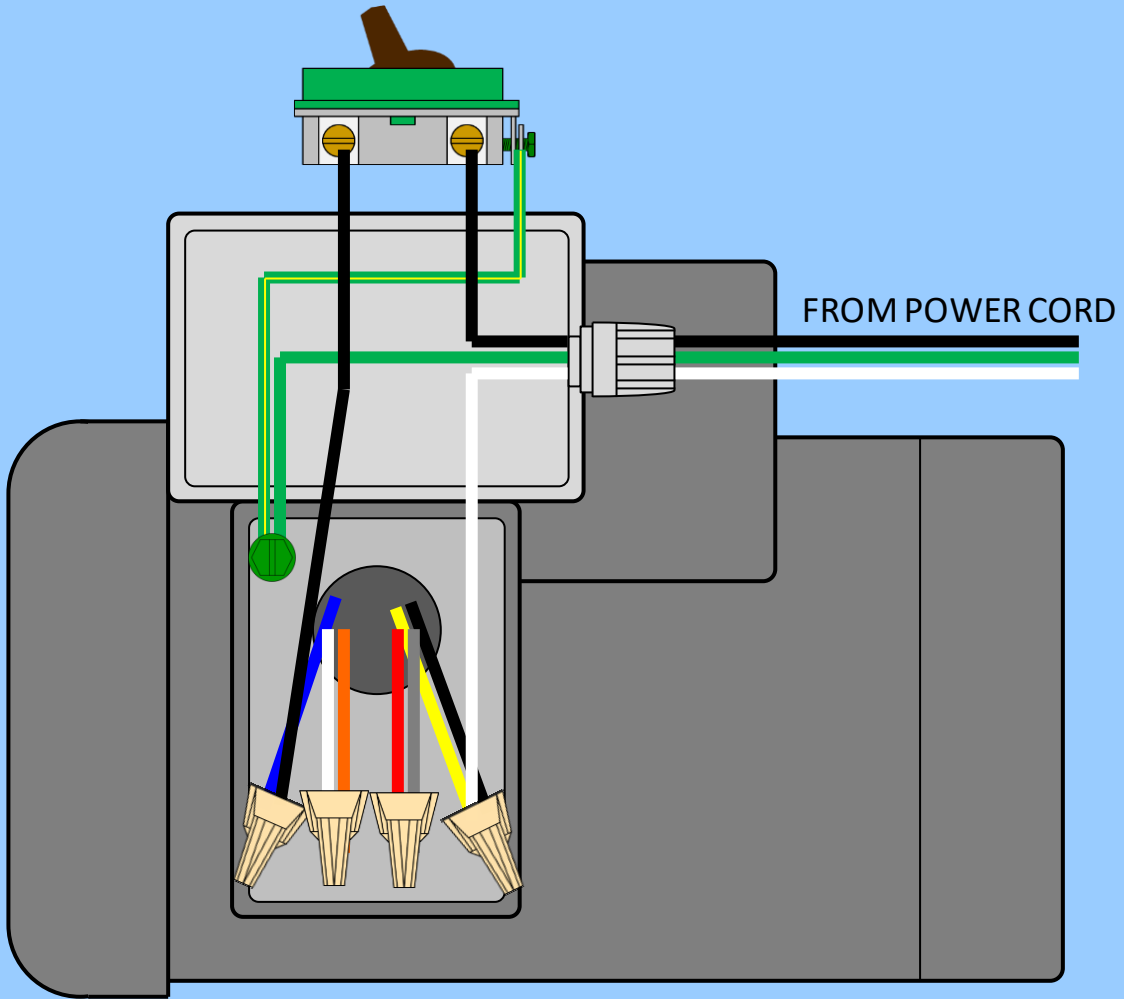

Note: Standard rotation is CCW facing end opposite shaft extension

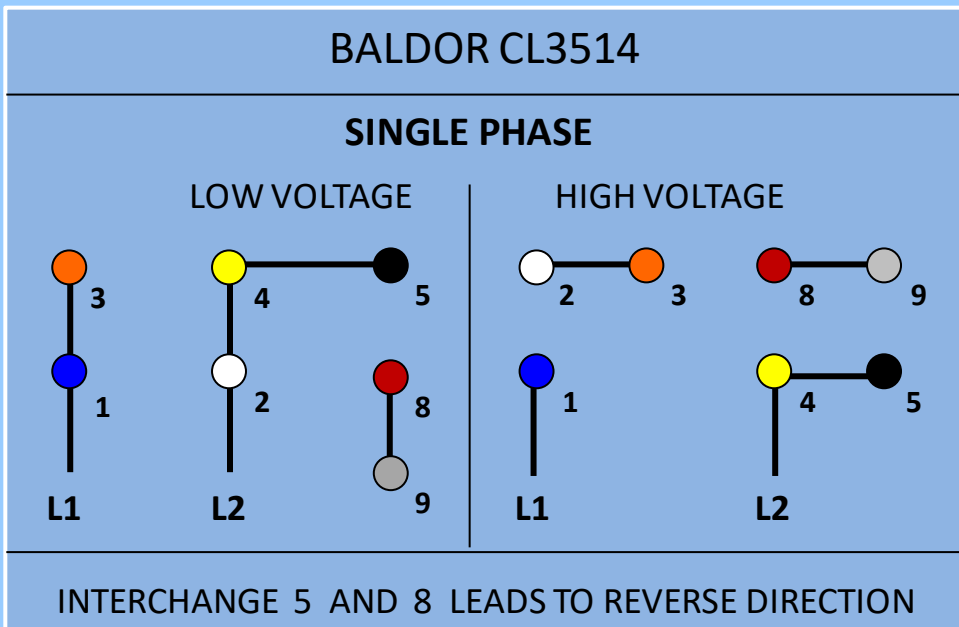

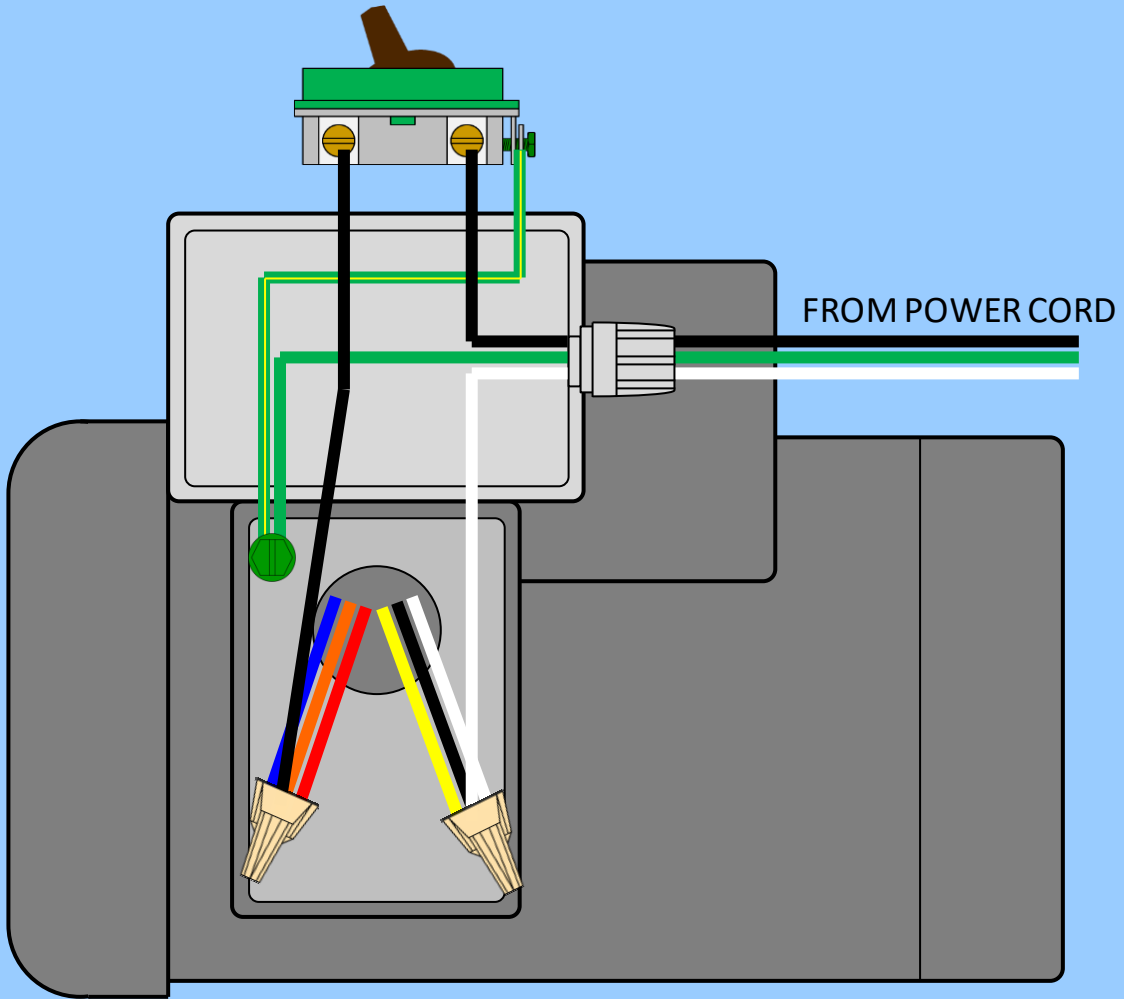

Note: Standard rotation is CCW facing end opposite shaft extension

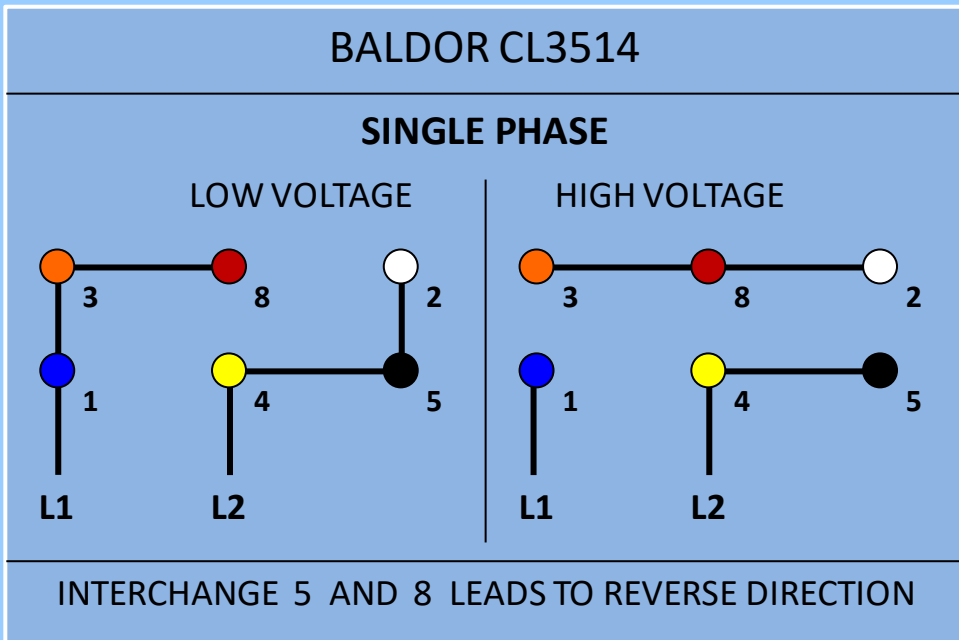

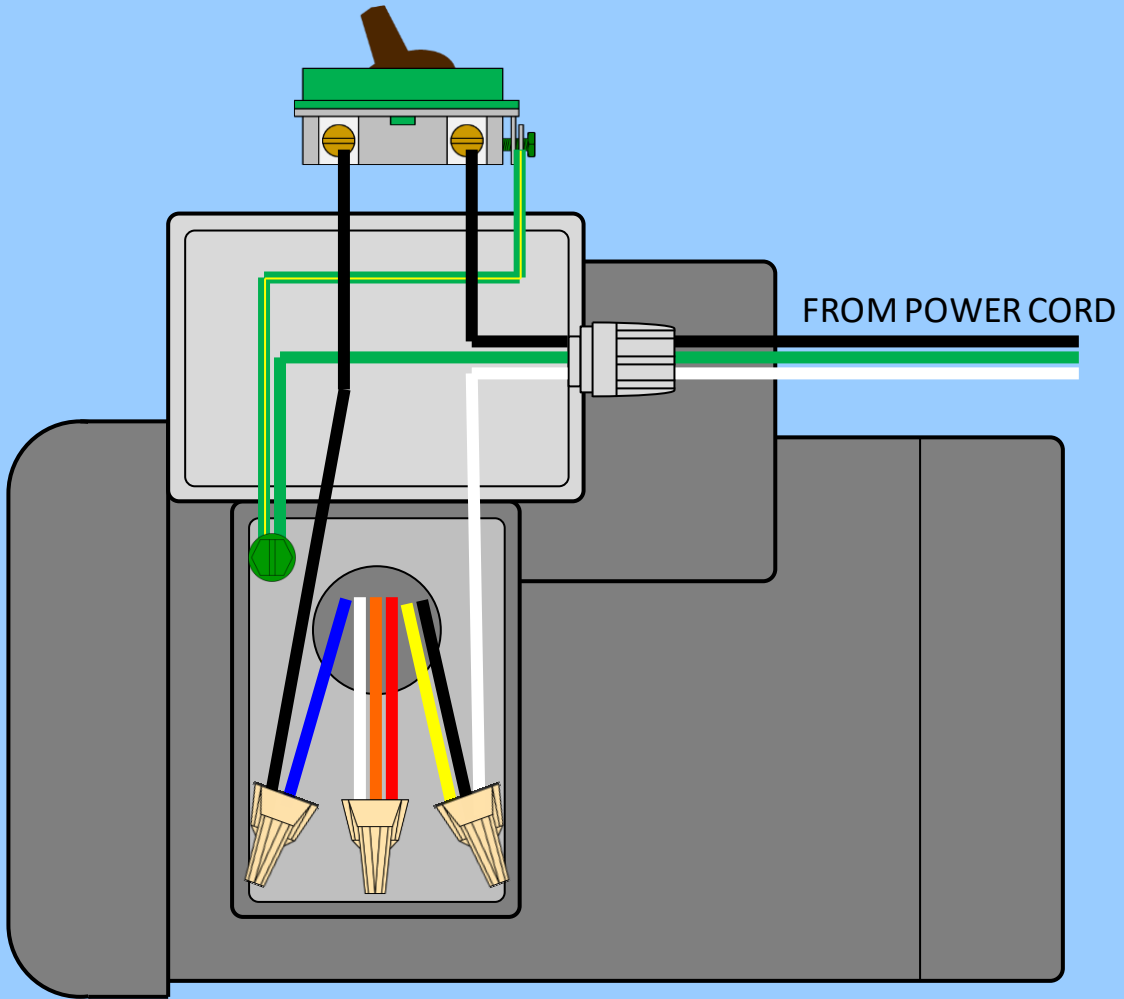

Note: Standard rotation is CCW facing end opposite shaft extension

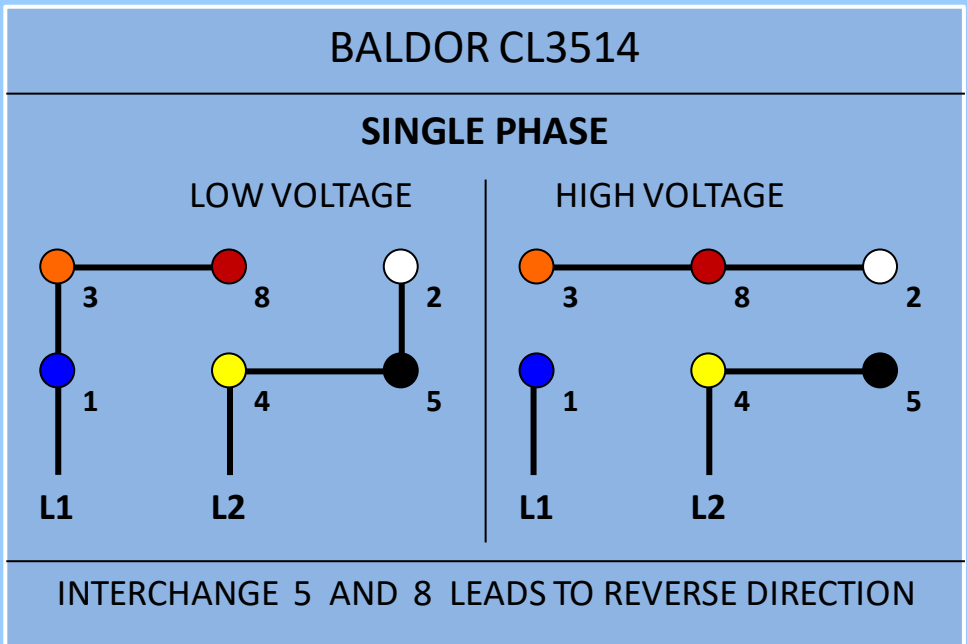

MARATHON G396 1 1/2 HP MOTOR

(Normal wiring, low voltage 120 VAC)

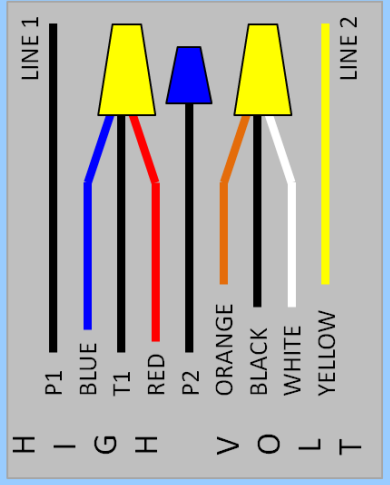
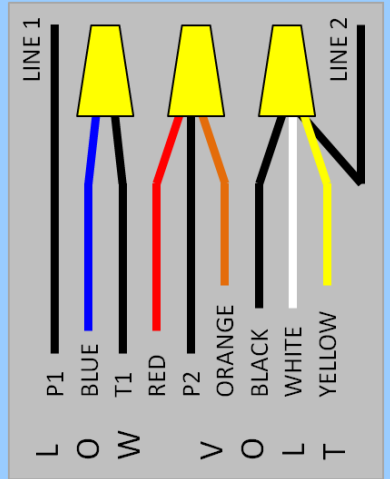
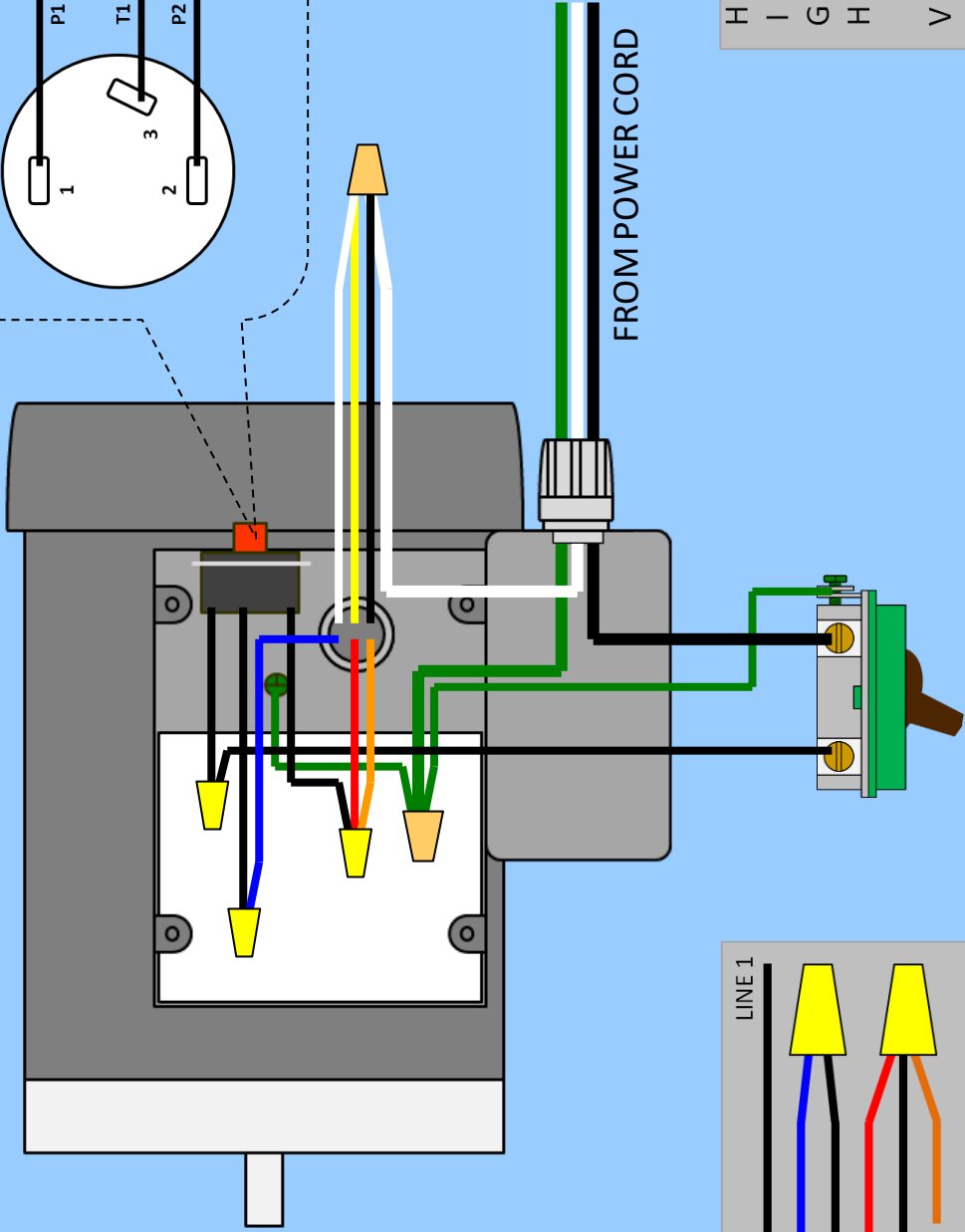
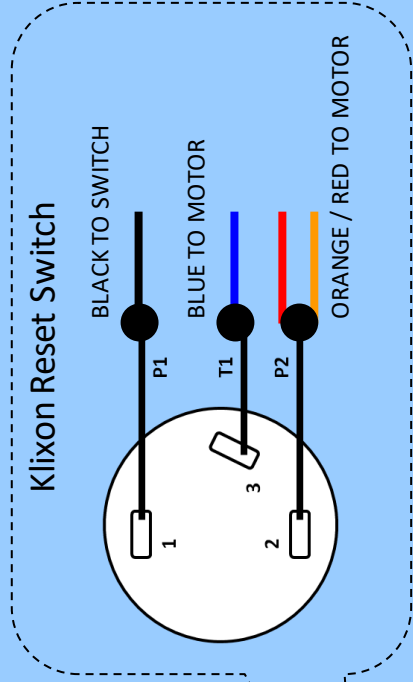

MARATHON G396 1 1/2 HP MOTOR

(High voltage wiring - 220 VAC)

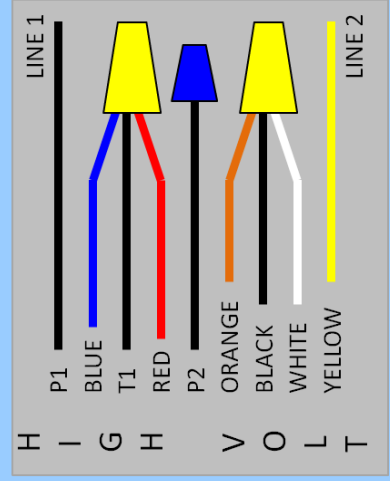
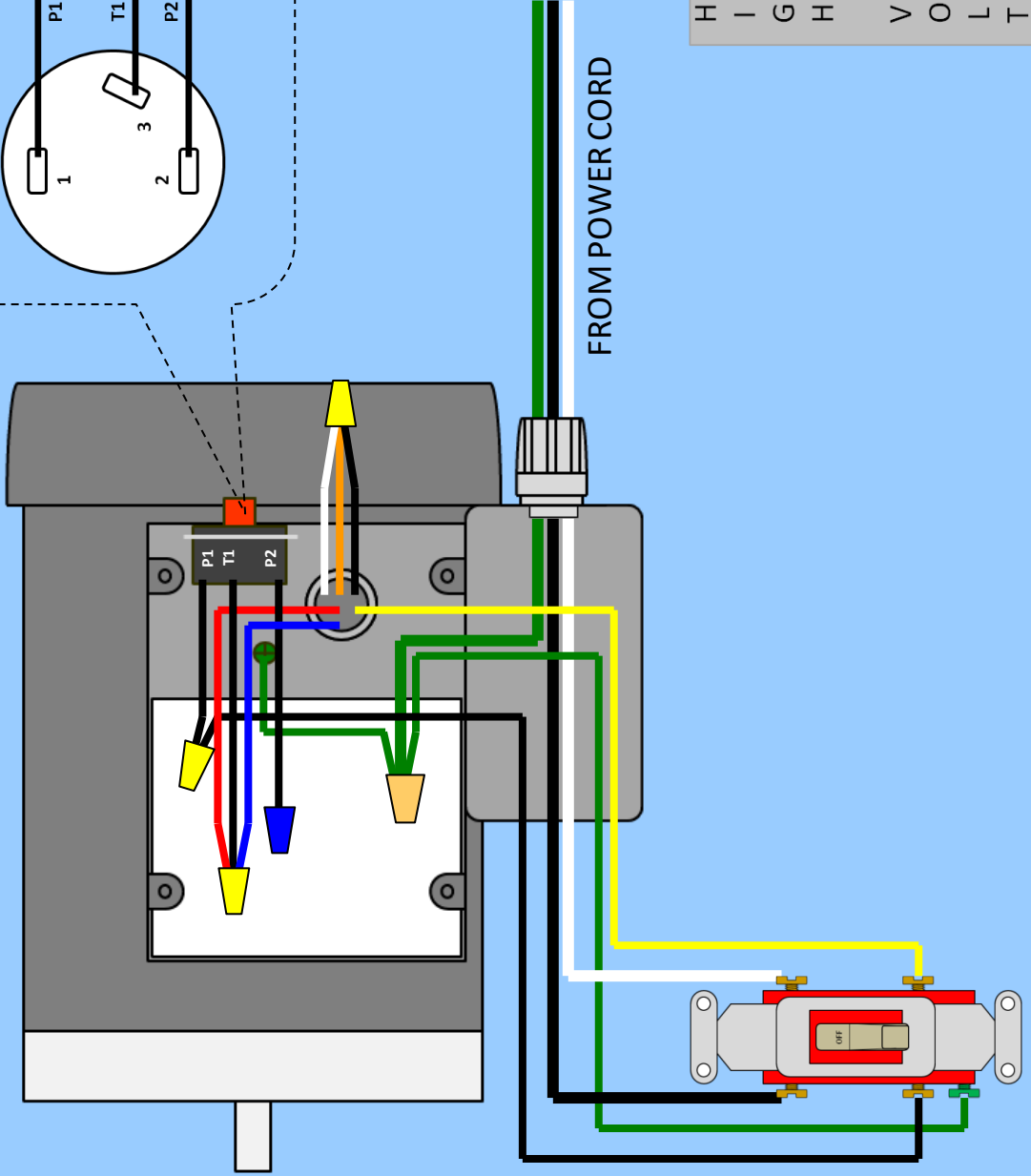
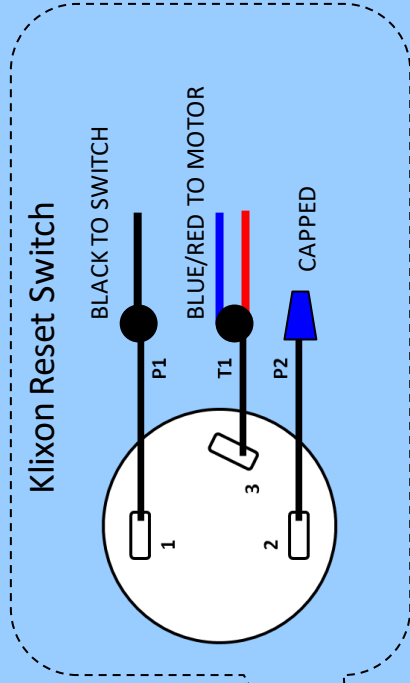

Troubleshooting

- A. PRESSURE DROP (NEW INSTALLATION)
- B. PRESSURE DROP AFTER MACHINE IS IN SERVICE
- C. PULSATION IN HOSE
- D. UNLOADER CYCLES RAPIDLY
- E. MOTOR STOPS AFTER SHORT DURATION
- F. PUMP MOTOR FAILS TO START
- G. PRESSURE FAILS TO DROP WHEN GUN VALVE IS CLOSED
- H. PUMP OIL DISCOLORATION
- I. WATER OR OIL LEAKING FROM BOTTOM OF PUMP
- J. WATER SUPPLY AND CONTAMINATION
- K. FREEZING OF PUMPS

A. PRESSURE DROP (new installation)

1. Inadequate water supply.

Improper nozzle size.

Consult manufacturer.

2. Air leak to strainer (filter bowl) or intake hose assembly.

Check for missing or damaged o-ring on filter bowl. Check quick coupler connection and quick coupler o-ring, check for damaged hose.

B. PRESSURE DROP AFTER MACHINE IS IN SERVICE

1. Unloader check valve scored or worn.

Install a rebuild kit or replace unloader.

2. Pump piston or plunger worn.

Install rebuild kit.

3. Damaged piston cylinders.

Install water sand filter.

4. Worn nozzle.

Replace with correct or same size nozzle.

5. Air leak to strainer (filter bowl) or intake hose assembly.

Check for missing or damaged o-ring on filter bowl. Check quick coupler connection and quick coupler o-ring, check for damaged hose.

6. Loose pump drive belt (if applicable).

Adjust tension to achieve ½" movement of belt at mid-point.

7. Clogged pick-up in the solution tank. *Clear clog.*

8. Pressure setting too high for motor/engine horse power

Lower pressure to 800 PSI (750 PSI Kruser)

9. Bypass valve open, partially open or leaking.

Position bypass valve properly or replace.

C. PULSATION IN HOSE (usually accompanied by a drop in pressure).

1. Water supply shortage or clogged pick-up in tank.

Increase pump water supply, clear clogged pick-up, Clean filter screen in intake strainer.

2. *Replace piston cups (on belt drive units).*

3. Stuck unloader piston or check valve in unloader

4. Obstruction in nozzle causing "false" unloader functions.

5. Pressure setting on unloader too high.

D. UNLOADER CYCLES RAPIDLY

1. Rapid in-out movement of unloader plunger.

Leak in high pressure line, gun leak, or a “weep” type gun is in use.

Defective poppet (nylon plunger in lower portion of unloader). Poppet may be deformed, pitted or sticking. Replace.

Scored unloader cup bore – replace unloader.

Plugged nozzle – clean/replace nozzle.

E. MOTOR STOPS AFTER SHORT DURATION

1. Thermal Overload tripped.

Check for low voltage, excessive drive belt tension, extension cord not adequate gauge for length or stuck starter switch in motor.

2. Excessive operating pressure.

Reduce pump operating pressure to manufacturers recommendation.

3. Defective motor start switch (inside of motor) or motor fails to reach operating speed & pressure.

Have an electrician verify motor condition.

4. Damaged motor fan housing.

Straighten dented or bent motor fan housing or replace

F. PUMP MOTOR FAILS TO START

1. No Power.

Check plugs, fuses and cords for contact.

2. Thermal overload on motor tripped out (if so equipped).

Check for low voltage on power supply, extension cord not adequate gauge for length, check belt for excessive tension, and check pump for excessive pressure on the unloader.

- 3 Excessive pressure in discharge hose.

Open gun valve to relieve pressure, check unloader for defects.

G. PRESSURE FAILS TO DROP WHEN GUN VALVE IS CLOSED

1. Defective unloading valve, sticking check valve.
Clean or replace, install seal kit.
2. Leak in gun, fittings or hose under high pressure.
Repair leak.

H. PUMP OIL DISCOLORATION

1. White foam – water in oil.

Drain and replace with CAT pump oil or temporarily with S.A.E. 30 non-detergent hydraulic oil. Faulty intake seals from wear or freezing, replace intake seals
2. Brown foam – rust & water.

Pump needs rebuilding if pressure is dropping and a rapid re-occurrence of foam in sight glass occurs after several hours of operation with fresh oil.

I. WATER OR OIL LEAKING FROM BOTTOM OF PUMP

1. Water – noticeable amounts.
Inlet water seals on pistons failing. See appropriate pump manual.
Cracked pump manifold from freezing – replace.
2. Oil – noticeable amounts.
Leak and failure of oil seals on pistons. Return to Siebrings for repair (notify to verify condition).
3. Leaking from pump oil fill cap
Oil level too far above red dot on the pump sight glass
Leaking pump intake seals allowing water into crank case of the pump

J. WATER SUPPLY AND CONTAMINATION

1. Sand from private wells or ponds.
Allow water sample to stand in clear glass bottle over night to observe sediment. Add intake line filter if in doubt.
2. High sulphur.
Brass parts may need replacement when used in high concentrations of sulphur or chelated iron.

K. FREEZING OF PUMPS

1. Water frozen in pumps will void warranty.

Winterizing mix = 50/50 mix of water and auto/RV anti-freeze or straight windshield washer fluid with a temperature rating well below the forecasted ambient low temperature.

If freezing conditions are suspect, always intake approximately 1 gallon of winterizing mix or until mix is expelled for gun discharge.

System Flush (Winterizing) Disconnect the supply line from the tank and place the end of the hose in a container with 50% water and 50% antifreeze, or straight windshield washer fluid (see above).

Start the unit and run until antifreeze flows out of the discharge of the pump, hose reel and gun.

Cover to protect from severe elements and/or rodents.

Pump mailing/shipping instructions:

Disconnect pump from motor. If problems are encountered, call for instructions in the best method to separate the hallow shaft pump from the motor.

Leave all valves, unloader and fittings connected to the pump.

Disconnect at hose reel.

Drain the pump oil.

Place in a sealed plastic bag and & box, package for sturdy handling.

Send to:

Siebring Manufacturing, Inc.

303 S. Main St.

George, IA. 51237

888-475-3317

<u>ITEM NO.</u>	<u>QTY</u>	<u>DESCRIPTION</u>
MD 1	1	¼" PARKER BALL VALVE
MD 2	2	¼" HOSE BARB, ⅜" NPT SHANK
MD 3	1	UNLOADER (SPECIFY PUMP MODEL)
MD 4	4	25 MP – ¼" MALE QUICK COUPLER
MD 5	3	25FS – ¼" FEMALE SOCKET – QUICK COUPLER
MD 6	1	1500 P.S.I. PRESSURE GAUGE
MD 7	2	HOSE REEL BEARING FLANGE (electric only)
MD 8	1	¼" BYPASS HOSE W/ENDS
MD 9	2	HOSE REEL BEARING (electric only)
MD10	1	⅜" X 24" PUMP TO HOSE REEL HOSE (⅜" END x ¼" END)
	1	226SWVL2652 Hose Reel Swivel
MD12	1	HAND GRIP ⅞"
MD13	1	⅜" X 24" BYPASS HOSE (¼" END x ¼" END)
MD14	1	RB-1214 ½" X ¼" PLASTIC REDUCING BUSHING
MD15	3	SE-12 90° PLASTIC STREET ELBOW
MD16	1	HOSE REEL (SPECIFY SPRAYER MODEL)
MD17	1	⅜" X 100' BRAIDED HOSE
MD18	2	WBH-12 ½" BULKHEAD FITTING
MD19	1	PLASTIC PLUG WITH ORIFICE
MD20	1	SUCTION FITTING ASSEMBLY
MD21	1	50MP – ½" MALE QUICK COUPLER
MD24	2	30 ¼ GUNJET GUN
MD25	1	50FS - ½" FEMALE SOCKET QUICK COUPLER
MD26	1	¾" X 24" SUCTION HOSE
MD27	1	½" LINE STRAINER COMPLETE
MD28	1	CAT PUMP MODEL # 2SF29ELS OR 2SF30GS
MD29	1	1 ½ HP MARATHON ELEC / 4 HP GAS
MD30	1	1 ½ HP TOGGLE SWITCH
MD31	1	ELECTRICAL CORD 120V 12/3
MD32	1	TOGGLE SWITCH BOX
MD34	4	4.10/3.50-4 WHEEL ASSEMBLY ¾" BEARING
MD50	1	T JET STRAINER, BRASS
MD51	1	WAND CORE
MD52	1	DISK
MD53	1	WAND CAP, BRASS
MD54	1	TOGGLE SWITCH BOX COVER
MD55	1	TIP 0° 00055, STAINLESS
MD56	1	TIP 15° 15055, STAINLESS
MD57	2	WAND EXTENSION, 18"
MD58	1	WAND EXTENSION, 12"
MD59	1	WAND EXTENSION, DRENCH HOOK
MD60	1	MISTING TIP, COMPLETE
MD61	1	SMALL PLASTIC WATER BREAKER
MD62	1	SMALL PLASTIC WATER BREAKER, COMPLETE
MD63	1	BACK FLUSH FITTING ASSEMBLY
MD65	1	FILTER BOWL (FOR ITEM MD27)
MD66	1	RUBBER GASKET (FOR ITEM MD27)
MD67	1	SCREEN (FOR ITEM MD27) 80 MESH (YELLOW), 50 MESH (BLUE)

MD 1

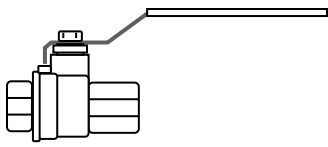

MD 10



MD 2

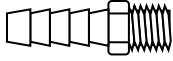

Swivel

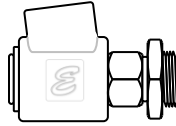

MD 21

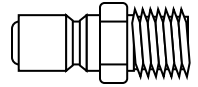

MD 3

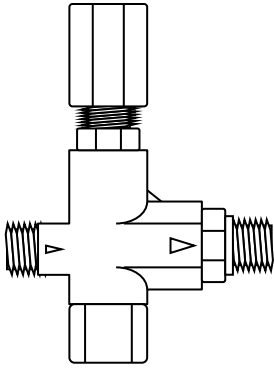

MD 12



MD 14



MD 4

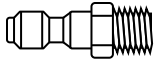

MD 13



MD 5

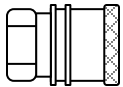

MD 15

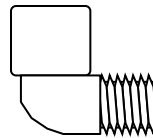

MD 24

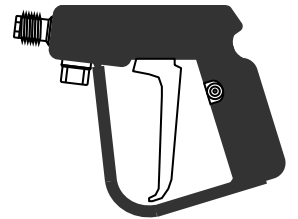

MD 6

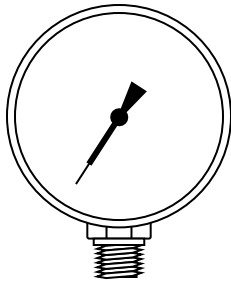

MD 16

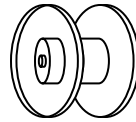

MD 25

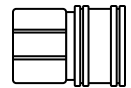

MD 7

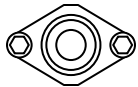

MD 17

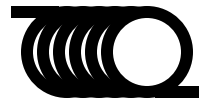

MD 26

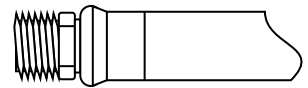

MD 8

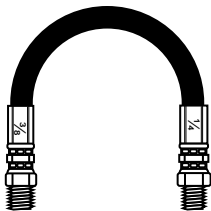

MD 18

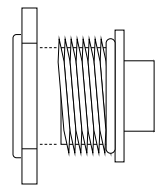

MD 9



Garden Hose Adapter

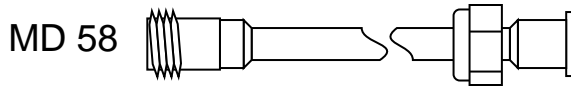
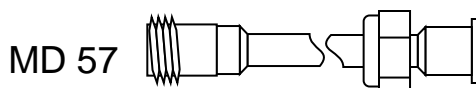
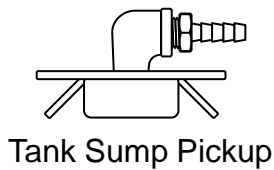
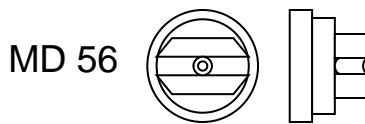
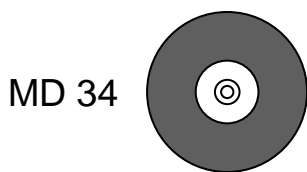
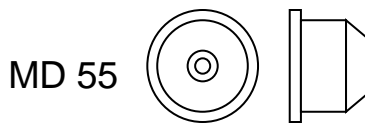
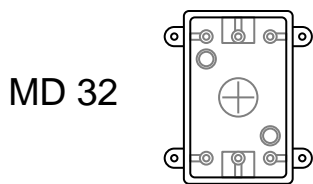
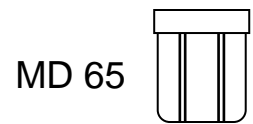
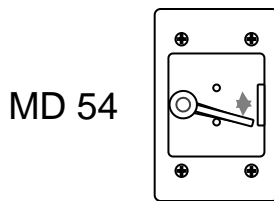
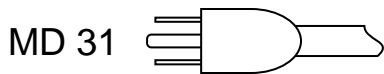
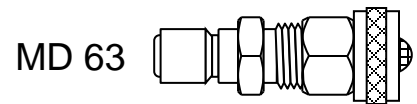
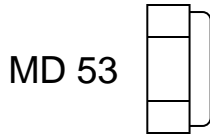
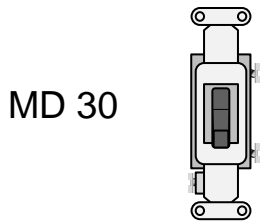
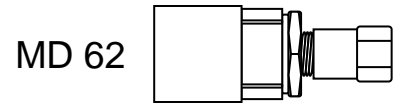
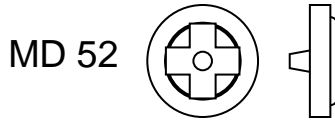
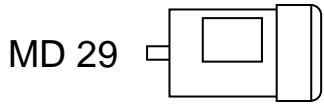
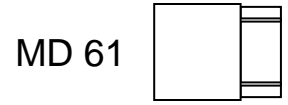
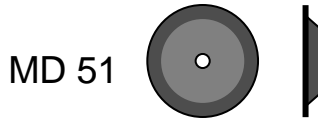
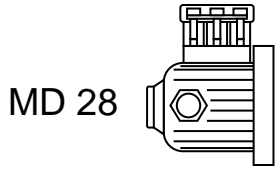
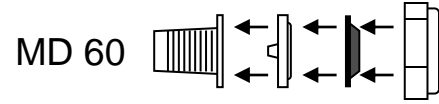
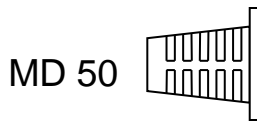
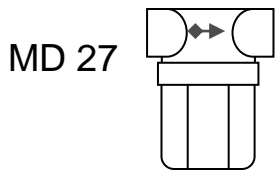

MD 59

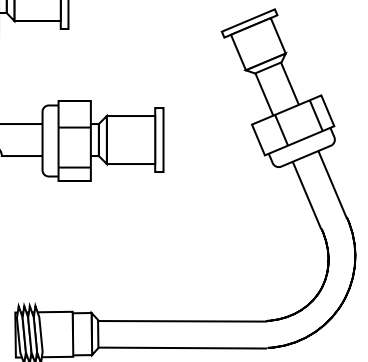

STAINLESS STEEL SPRAYER

PARTS – FOX, COYOTE, MIST'R'DRENCH

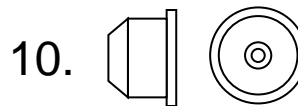
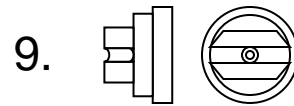
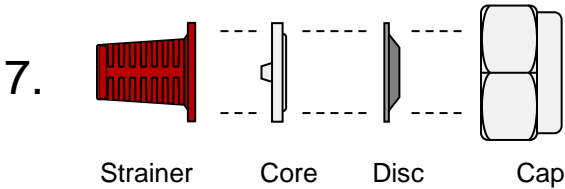
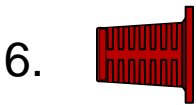
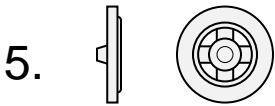
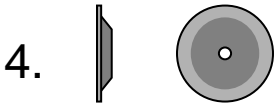
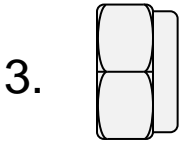
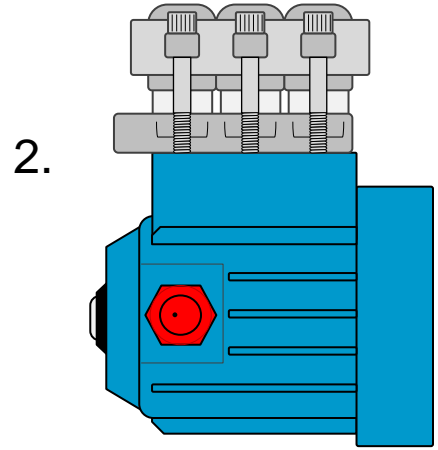
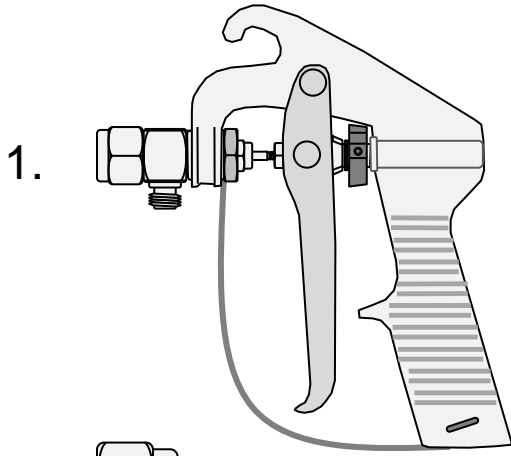

ITEM	PART / MDL NUMBER	DESCRIPTION
1	014SSGUNJETGUN	SS SPRAY GUN
2	PUMP - 2SF15SEEL	KRUSER/FOX JR.
3	014CAPSSCP	SS CAP
4	014D4DISKONL	DISK
5	014CREONLY45	CORE
6	014NYLONSTRAINER	NYLON STRAINER
7	ASMMDMISTSS	SS MISTING TIP COMPLETE
8	01418SSEXTN	18" WAND EXT. ANGLED
9	014TIPSSTLLA	15° TIP
10	014TIPSSTLLA	0° TIP

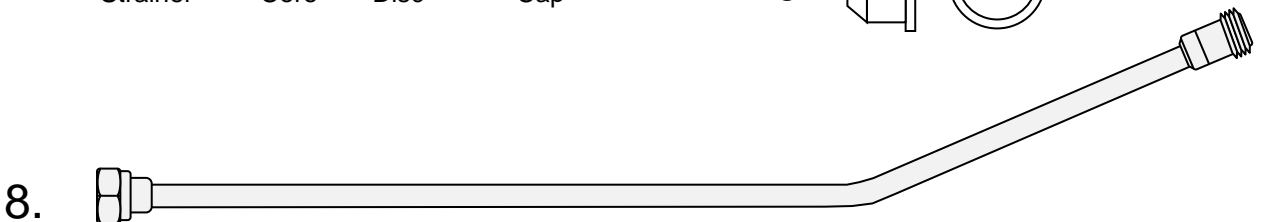

ALL SPRAYERS & PRESSURE WASHERS

CAUTION

TO COMPLETELY PROTECT FROM FREEZING, BLOW ALL WATER OUT WITH AIR PRESSURE. THEN SUCK IN 1 QUART OF ANTIFREEZE WITH A SHORT INTAKE HOSE. THEN BLOW AIR INTO INTAKE VALVES UNTIL ANTIFREEZE APPEARS AT THE END OF DISCHARGE HOSE.



WARNING

HIGH PRESSURE WATER INJECTION HAZARD EXISTS.

Do not allow water to contact the human body. Under high pressure, it will penetrate the skin and can cause serious infection or injury.

This unit to be operated only by competent, cautious personnel.

WARNING

USE EXTREME CARE WHEN OPERATING THIS MACHINE. DO NOT ALLOW WATER TO CONTACT THE HUMAN BODY BECAUSE WATER UNDER HIGH PRESSURE IS DANGEROUS. IT WILL PENETRATE SKIN AND CAN CAUSE SERIOUS INFECTION OR INJURY. UNIT TO BE OPERATED ONLY BY COMPETENT, CAUTIOUS PERSONNEL.

**Not Intended for
Highway Use
Maximum Speed
20 MPH**

CAUTION

STRAINER GASKET AT TOP OF BOWL MUST BE IN PLACE FOR PUMP TO WORK PROPERLY.

CAUTION

Rinse pump and tank after each use

CAUTION

Do not run pump with gun closed for more than 2 minutes.

CAUTION

OPERATE ONLY IN WELL VENTILATED AREA UNLESS UNIT IS VENTED TO OUTSIDE

BACK FLUSH ASSEMBLY

THIS ACCESSORY IS TO BE USED FOR FLUSHING THE PUMP AND ASSOCIATED PLUMBING, AND FOR TROUBLESHOOTING AND LEAK CHECKING THE SYSTEM.

GAS ENGINE UNITS & HOT WASHERS

MR. DRENCH & FOX SPAYERS

